

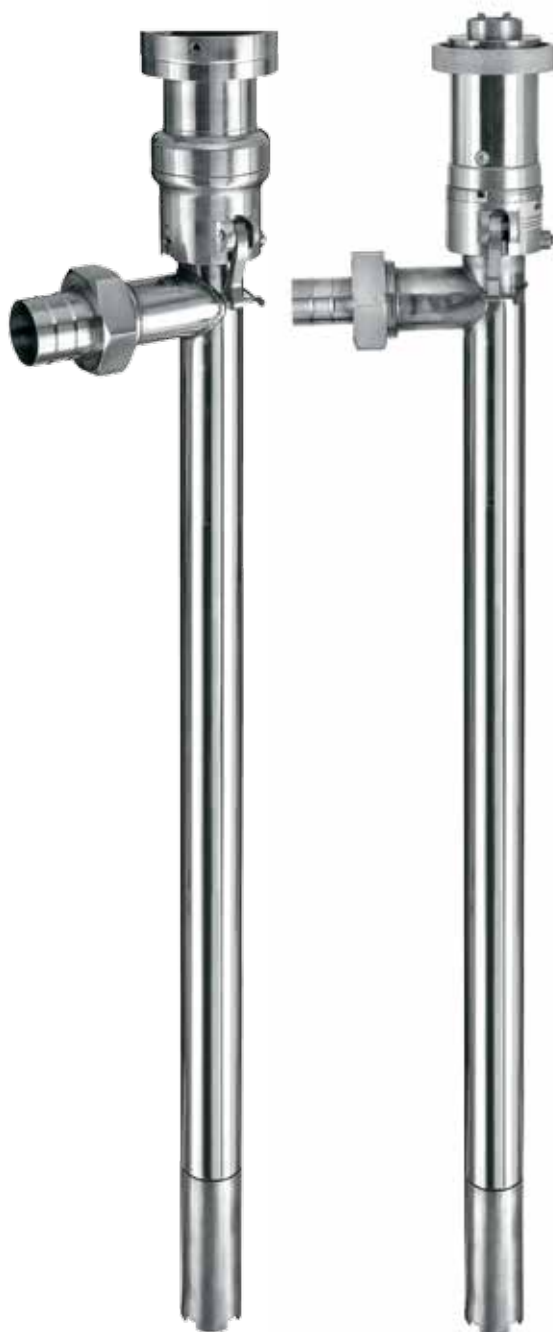

FINISH THOMPSON INC.

HVDP SERIES PUMPS

OPERATION, INSTALLATION & PARTS MANUAL





FINISH THOMPSON INC.

921 Greengarden Road • Erie, PA 16501-1591 U.S.A.

Ph 814-455-4478 • Fax 814-455-8518

Email fti@finishthompson.com • www.finishthompson.com

EU Declaration of Conformity



Finish Thompson Inc. hereby declares that the following machine(s) fully comply with the applicable health and safety requirements as specified by the EU Directives listed. The product may not be taken into service until it has been established that the drive motor for the Drum and Container Pump complies with the provisions of all relevant EU Directives. The complete product complies with the provisions of the EU Directive on machinery safety provided motors manufactured by Finish Thompson Inc. are used.

This declaration is valid provided that the devices are fully assembled and no modifications are made to these devices.

Type of Device:

Drum and Container Pump Tubes

BTS - 40	EPPI/EPPS 15/27/40	EFV/EFV/EFV-16/27/40/48/54
HVDP LR-27/40/48	HVDP HR-27/40/28	PFM-27/40/48/60
PFP-15/27/40/48/60/72	PFS-27/40/48/60/72	PFV-27/40/48/60/72
TBP-27/40/48	TBS-40	TTC/TTS-27/40/48
STTS-40	TMS-40	

Models:

EU Directives:

Machinery Safety (2006/42/EC)

Applied Harmonized Standards:

EN ISO 12100

EN 809

Manufacturer: Finish
Thompson Inc.
921 Greengarden Road
Erie, Pennsylvania 16501-1591 U.S.A

Signed,

President

1 August 2016

Person(s) Authorized to Compile Technical File: Finish Thompson GmbH
Otto-Hahn-Strasse 16
Maintal, D-63477 DEU
Telephone: 49 (0)6181-90878-0

Introduction

This manual pertains to the HVDP Series drum pumps. Finish Thompson Inc. thanks you for choosing our products. We believe the use of our products will be fully satisfactory. When properly installed and operated, your Finish Thompson motor and pump will provide long, trouble-free service; therefore, please read this manual carefully before carrying out any operations on the pump/motor unit. Any use other than that described herein is considered incorrect; and, consequently, Finish Thompson Inc. shall not be held responsible for any damages to people or property. In case of doubt or enquiries, please reply to our Technical Service department directly at the following address:

Finish Thompson, Inc.
921 Greengarden Rd.
Erie, PA 16501 U.S.A.
Tel. 1-814-455-4478; Fax 1-814-455-8518
www.finishthompson.com; fti@finishthompson.com

Index

Introduction	3
Warranty, General Terms & Conditions	4
Safety	5
Important Safety Information for Pumping Flammable or Hazardous Substances	6
HVDP Terminology	7
HVDP Series Assembly, Removal, and Operation	8
HVDP Series Stator Removal, Inspection, and Installation	9
HVDP Series Drive Removal, Inspection, and Installation	9
HVDP Series Rotor Removal, Inspection and Installation	10
HVDP Series Seal Removal, Inspection and Installation	10
HVDP-HR Series Parts Schematic	11
HVDP-LR Series Parts Schematic.....	12

Technical Service Hotline: 1-800-888-3743 or email techservice@finishthompson.com

Warranty, General Terms & Conditions

1. The following terms and conditions apply to the sale of machinery, components and related services and products, of Finish Thompson Inc. (hereinafter “the products”)
2. Finish Thompson Inc. (the manufacturer) warrants only that:
 - a) its products are free of defects in material, design and workmanship at the time of original purchase;
 - b) its products will function in accordance with Finish Thompson Inc. operation manuals; Finish Thompson Inc. does not guarantee that the product will meet the precise needs of the Customer, except for those purposes set out in any invitation to render documents or other documents specifically made available to Finish Thompson Inc. before entering into this agreement;
 - c) high quality materials are used in the construction of the pumps and that machining and assembly are carried out to the highest standards. Except as expressly stated above, Finish Thompson Inc. makes no warranties, express or implied, concerning the products, including all warranties of fitness for a particular purpose.

This warranty shall not be applicable in circumstances other than defects in material, design, and workmanship. In particular warranty shall not cover the following:

- d) Periodic checks, maintenance, repair and replacement of parts due to normal wear and tear;
- e) Damage to the product resulting from:
 - i. Tampering with, abuse or misuse, including but not limited to failure to use the product for its normal purposes as stated at the time of purchase or in accordance with Finish Thompson, Inc. instructions for use and maintenance of the product, or the installation or improper ventilation or use of the product in a manner inconsistent with the technical or safety standard in force;
 - ii. Repairs performed by non-authorized service workshop, or opening of the unit by non-authorized personnel, or use of non genuine Finish Thompson Inc. parts;
 - iii. Accidents, force majeure or any cause beyond the control of Finish Thompson Inc., including but not limited to lightning, water, fire, earthquake, and public disturbances, etc.
3. The warranty shall cover the replacement or repair of any part, which is documented to be faulty due to construction or assembling, with new or repaired parts free of charge delivered by Finish Thompson, Inc. Parts subjected to normal wear and tear shall not be covered by the warranty. Finish Thompson, Inc. shall decide as to whether the defective or faulty part shall be replaced or repaired. Transportation charges are prepaid to Finish Thompson.
4. The warranty of the products shall be valid for a period of **12 months** from the date of delivery, under the condition that notice of the alleged defect to the products or parts thereof be given to Finish Thompson, Inc. within the term of 8 days from the discovery.
5. Repair or replacement under the terms of this warranty shall not give a right to an extension to, or a new commencement of, the period of warranty. Repair or replacement under the terms of this warranty may be fulfilled with functionally equivalent re-conditioned units. Finish Thompson Inc. qualified personnel shall be solely entitled to carry out repair or replacement of faulty parts after careful examination of the motor. Faulty parts or components when replaced by Finish Thompson Inc. will become the property of Finish Thompson Inc. If this warranty does not apply, the purchaser shall bear all cost for labor, material and transportation.
6. Finish Thompson Inc. will not be liable on any claim, whether in contract, tort, or otherwise, for any indirect, special, incidental, or consequential damages, caused to the customer or to third parties, including loss of profits, process down time, transportation costs, costs associated with replacement or substitution products, labor costs, installation or removal costs. In any and all events, manufacturer’s liability shall not exceed the purchase price of the product and/or accessories.
7. **Return Policy.** Should you have any problems with this product, please contact the distributor in your area. The distributor will determine if a return to the factory is necessary and will contact the factory for a Return Authorization Number. Otherwise, contact our Technical Service Hotline (1-800-888-3743) or e-mail techservice@finishthompson.com if you have any questions regarding product operation or repair.

Warranty Registration

Thank you for your purchase of this quality Finish Thompson product. Be sure to take a minute to register your pump at Finishthompson.com/warranty. Simply provide the model number, serial number and a few other pieces of information.

Safety

1. Introduction

This manual contains all the information needed for the correct installation, use and maintenance of your new Finish Thompson pump. It should be read and understood by all the personnel involved in installation, operating and servicing of the pump before it is started.

2. Operator Qualification and Training

The personnel in charge of the installation, the operation, and the maintenance of the pump must be qualified and able to perform the operations described in this manual. Finish Thompson, Inc. shall not be held responsible for the training level of personnel and for the fact that they are not fully aware of the contents of this manual.

3. Safety Instructions

FOR YOUR OWN SAFETY

BEFORE using or servicing your pump, please make sure to wear the proper clothing, eye protection and follow standard safety procedures when handling corrosive or personally harmful materials.

ALWAYS use and store the pump and motor in an upright position.

DANGER: POWER SUPPLY

Refer to instructions in the appropriate motor Operation & Installation Manual.

4. Noise Level

Refer to specifications in the appropriate motor Operation & Installation Manual.

5. Modifications and Spare Parts

Any changes concerning the service of the pump as originally purchased can be executed only after written approval from Finish Thompson Inc. It is recommended to use only genuine Finish Thompson Inc. spare parts and approved accessories. The use of non-original spare parts or non-approved accessories will void warranty and removes any responsibility on the manufacturer's behalf for any damage caused to people or things.

6. Cleaning

It is highly recommended to flush pumps with clean water or some other neutralizing fluid compatible with pump materials when done pumping or when switching chemicals.

ALWAYS re-lubricate the pump internals & rotor after cleaning.

IMPORTANT SAFETY INFORMATION FOR PUMPING FLAMMABLE OR HAZARDOUS SUBSTANCES

Read these instructions before operating the pump and motor equipment. The manufacturer will not be responsible for any damage to property or to persons caused by improper use of the equipment.

- ⚠ WARNING:** It is the responsibility of the user to operate the pump in conformance with OSHA rules for dispensing liquids. Pump containers should be grounded when using with flammable or combustible liquids to avoid static electricity.
1. Use only an explosion-proof rated electric or non-electric (air) motors on stainless steel pump tubes with a Static Protection Kit when transferring flammable or combustible liquids.
- ⚠ WARNING:** Never use an open, splash-proof, TEFC, battery-operated or non-explosion-proof rated motor or a plastic pump tube when transferring flammable or combustible liquids.
2. When operating a drum pump (especially when pumping flammable, combustible or hazardous liquids) follow all electrical and safety codes.
 - a) In the United States: the United States Occupational Safety and Health Act (OSHA), most recent National Electrical Code (NEC), National Fire Protection, Inc. (NFPA) Code 30 (Flammable and Combustible Code), NFPA 77 (Static Electricity), NFPA 251 (Standard Method of fire Test of Building Construction), NFPA 704 (Identification of the Fire Hazards of Materials), and other NFPA codes, local codes and ordinances.
 - b) Outside the United States: the ATEX equipment directive 2014/34/EU where applicable, the ATEX workplace 99/92/EC directive where applicable, in addition the precautions of the U.S. codes listed herein and all other local codes and ordinances.
 3. Pumping hazardous, flammable, or combustible liquids should only be done in buildings, rooms, or areas suited for this purpose. (See NFPA 30, NFPA 78, NFPA 80, NFPA 251, NFPA 704, other suitable NFPA codes, OSHA, ATEX workplace 99/92/EC directive insurance companies, and other local codes and ordinances.)
 4. When filling cans, drums, etc. with combustible or flammable liquids, both container pumping from and container pumping to, should be bonded and grounded to dissipate possible accumulations of static electricity, and minimize sparks caused by static electricity (refer to NFPA 77 and CLC/TR 60079-32-1 for specific details).
- ⚠ WARNING:** Avoid splashing. Splash filling can create static electricity and is extremely hazardous. Reduce motor speed to prevent splashing.
- ⚠ WARNING:** Fluid velocity must be 3 feet/.9 meter/second maximum (7 gpm/26.5 lpm in 1" hose and 4 gpm/15 lpm in ¾" hose) to reduce risk of static electricity. Reduce motor speed to reduce the fluid velocity.
5. Before using, confirm that the pump and any accessories (hose, nozzle, flow meter, etc.) materials of construction are suitable for the material to be pumped and that the maximum temperature is not exceeded.

INFORMATIONS IMPORTANTES SUR LA SÉCURITÉ DURANT LE POMPAGE DE SUBSTANCES INFLAMMABLES OU DANGEREUSES

Veuillez lire attentivement ces instructions avant d'utiliser la pompe et l'équipement du moteur. Le fabricant ne sera pas tenu responsable des dommages matériels ou corporels causés par une utilisation inappropriée de l'équipement.

- ⚠ AVERTISSEMENT:** Il est de la responsabilité de l'utilisateur de faire fonctionner la pompe conformément aux règles OSHA (Santé et Sécurité au Travail) relatives à la distribution de liquides. Les conteneurs de pompes doivent être électriquement mis à la terre lors de l'utilisation de liquides inflammables ou combustibles afin d'éviter toute électricité statique.
1. Lors du transfert de liquides inflammables ou combustibles, utilisez uniquement des moteurs électriques ou non électriques (pneumatiques) antidéflagrants sur des tubes de pompe en acier inoxydable dotés d'un dispositif de protection antistatique.
- ⚠ AVERTISSEMENT:** N'utilisez jamais de moteur ouvert, à l'épreuve des éclaboussures, TEFC, alimenté par piles ou non antidéflagrant, ni un tube de pompe en plastique lors du transfert de liquides inflammables ou combustibles.
2. Lors de l'utilisation d'une pompe à tambour (en particulier lors du pompage de liquides inflammables, combustibles ou dangereux), respectez tous les codes électriques et les codes de sécurité.
 - a) Aux États-Unis : Loi américaine sur la sécurité et la santé au travail (OSHA); le code national de l'électricité (NEC) le plus récent; le code 30 de la NFPA (code d'inflammabilité et de produits combustibles); le code NFPA 77 (électricité statique); le code NFPA 251 (Méthode standard de test d'incendie de la construction de bâtiments); le code NFPA 704 (Identification des risques d'incendie des matériaux) et autres codes et règlements de la NFPA.
 - b) En dehors des États-Unis : La directive sur les équipements ATEX 2014/34 / EU, le cas échéant, la directive ATEX sur le lieu de travail 99/92 /EC, le cas échéant, ainsi que les précautions des codes des États-Unis énumérés dans la présente et de tous les autres codes, lois et règlements locaux.
 3. Le pompage de liquides dangereux, inflammables ou combustibles ne doit être effectué que dans des bâtiments, des pièces ou des zones adaptées à cet usage. (Voir NFPA 30, NFPA 78, NFPA 80, NFPA 251, NFPA 704, autres codes NFPA appropriés, OSHA, les directives des compagnies d'assurance ATEX 99/92 /CE, et autres codes, lois et règlements locaux.)
 4. Lors du remplissage de bidons, fûts, etc. avec des liquides combustibles ou inflammables, les conteneurs d'où le liquide est pompé et le conteneur recevant le liquide doivent être reliés et mis à la terre pour éviter toute accumulation éventuelle d'électricité statique et minimiser ainsi les étincelles causées par l'électricité statique (voir NFPA 77). et CLC / TR 60079-32-1 pour des détails spécifiques).
- ⚠ AVERTISSEMENT:** Évitez les éclaboussures. Les éclaboussures peuvent créer de l'électricité statique et sont extrêmement dangereuses. Réduisez la vitesse du moteur pour éviter les éclaboussures.
- ⚠ AVERTISSEMENT:** La vitesse du fluide doit être au maximum de 3 pieds / 0,9 mètre / seconde (7 gpm / 26,5 lpm dans un tuyau de 1"; et 4 gpm / 15 lpm dans un tuyau de ¾") afin de réduire le risque d'électricité statique. Réduisez la vitesse du moteur afin de réduire ainsi la vitesse du fluide.
5. Avant utilisation, assurez-vous que les matériaux de la pompe et des accessoires (tuyau, ajutage, débitmètre, etc.) sont compatibles avec le fluide et que la température maximale n'est pas dépassée.

HVDP TERMINOLOGY

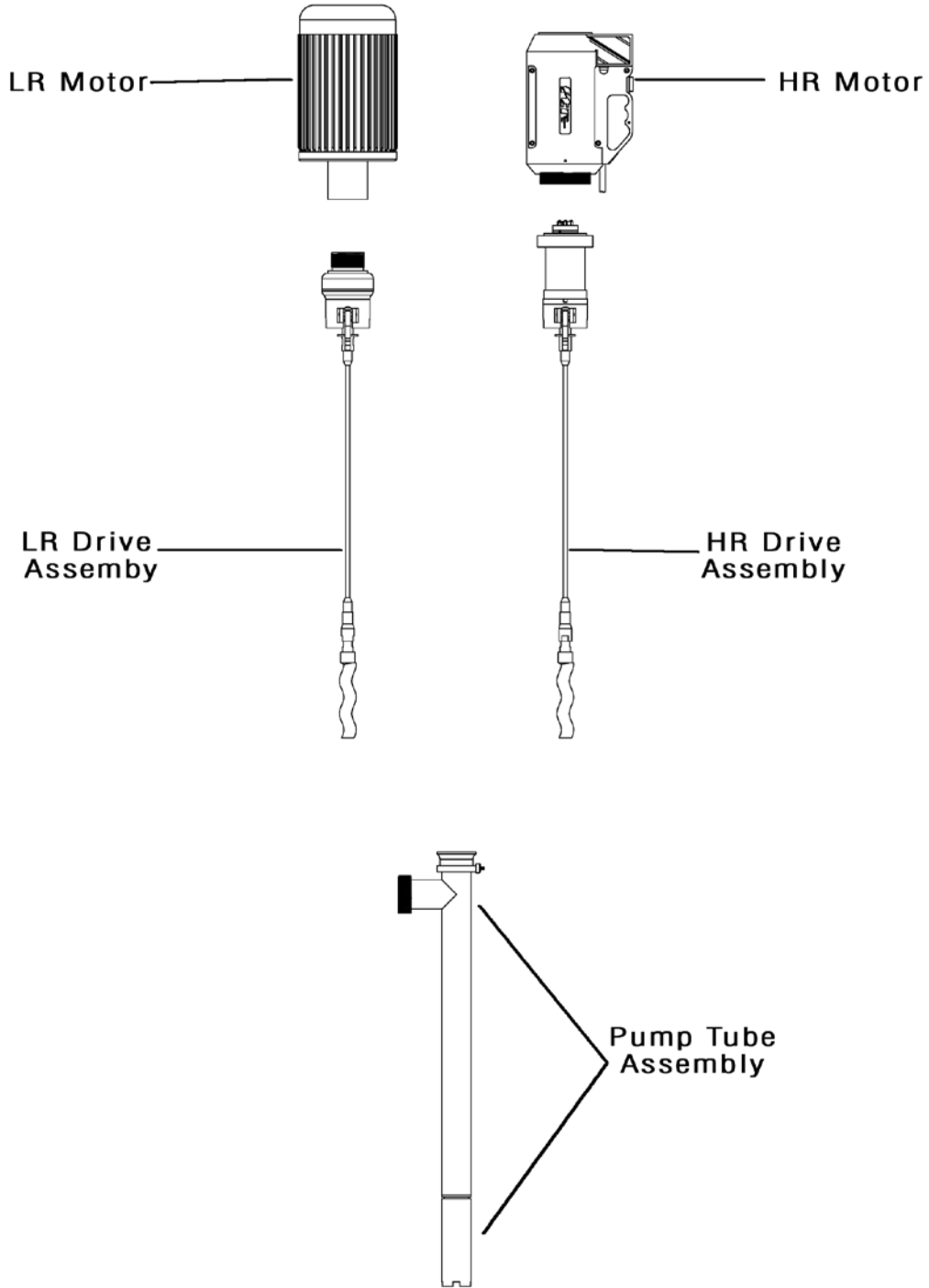

ASSEMBLY & OPERATION INSTRUCTIONS

SECTION 1: MOTOR INSTALLATION AND REMOVAL

INSTALLATION - HVDP-HR

1. Locate the rubber coupling insert that was separately shipped in a plastic bag (see Figure 1).
2. Install the rubber coupling insert onto the metal coupling half located on top of the HR drive assembly.
3. Find the metal coupling half located inside the HR motor. Align this coupling with rubber insert installed in the second step of these instructions.
4. Slide the HR motor onto the HR drive assembly.
5. Hand tighten the motor nut onto the threaded nose of the HR motor.

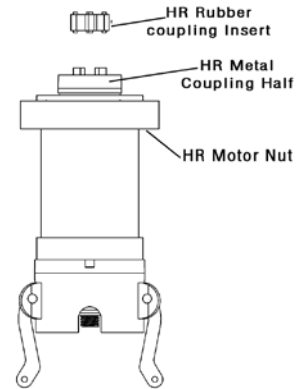

Figure 1

REMOVAL - HVDP-HR

1. To remove the HR motor, reverse HR motor installation instructions found in this section.

INSTALLATION - HVDP-LR

1. Check the rotation direction of the LR motor (air and induction motors) before installing the motor onto the pump.
⚠ WARNING: Motor rotation must be clockwise when viewed from the fan end of the motor. Rotating the motor in the wrong direction will cause damage to the pump.
2. Remove the motor adapter bolts (see Figure 2) and separate the motor adapter from the motor.
3. Thread the motor adapter onto the LR drive assembly. Hand tighten the motor adapter.
Note: Threads are left-handed. Also, thread lubricant is recommended to ensure smooth, bind free assembly.
4. The LR motor coupling consists of two 5/16" diameter pins welded to a hub. The LR drive assembly coupling has two slots that receive these pins. Align the pins of the motor coupling with the slots on the drive assembly coupling and slide the motor onto the drive assembly.

Note: Make sure the coupling is engaged properly and the motor adapter face is flush with the motor face.

5. Rotate the motor until the motor adapter mounting holes align with the threaded holes in the motor face.
6. Install the motor adapter bolts and torque to approximately 7 ft.-lbs. (9.5 N•M)

REMOVAL - HVDP-LR:

1. Remove the LR motor adapter bolts.
2. Remove the LR motor.

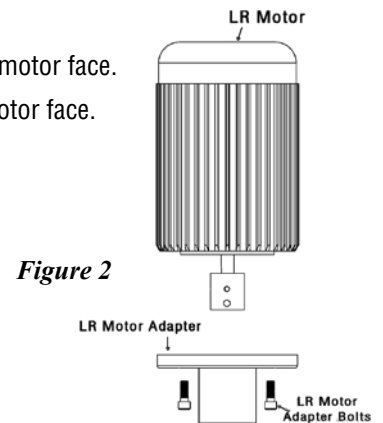

SECTION 2: OPERATION

1. Make sure the motor (electric or air) is properly installed on the pump tube and is in the off position. See motor instruction above for installation instructions.
2. Insert the pump tube into the fluid to be dispensed and the hose into the container to be filled prior to starting the pump. Bung adapters are available to provide a tighter fit between the pump tube and bung opening of a standard drum. Check drum pump accessories at www.finishthompson.com or contact your local Finish Thompson distributor for bung adapter info.
3. Make sure the pump's discharge hose is properly secured before operating the motor.
4. Begin pumping by turning the motor on and verifying that there are no leaks. If leaks are noticed immediately turn the motor off and check all discharge hose connections.

NEVER allow the pump to run dry.

NEVER operate the pump against a closed discharge. If the pump is operated against a closed discharge, a bypass (pressure relief valve) must be used.

NEVER pump liquids containing solids that can damage internal pump parts (i.e. metal chips). Pumping solids can lead to increased wear on the stator and rotor.

SECTION 3: STATOR REMOVAL, INSPECTION & INSTALLATION

REMOVAL:

1. The stator is located at the bottom of the pump tube assembly (see Figure 5).
2. Remove the stator by unthreading it from the pump tube. If the stator cannot be unthreaded by hand, insert a screwdriver into the slots found at the bottom of the stator. Use the screwdriver to rotate the stator.

Note: The stator has left hand threads.

INSPECTION:

1. Inspect the stator for gouging and excessive wear. Contact FTI if you are questioning the condition of the stator.

INSTALLATION:

1. Reverse the removal instructions found in this section.

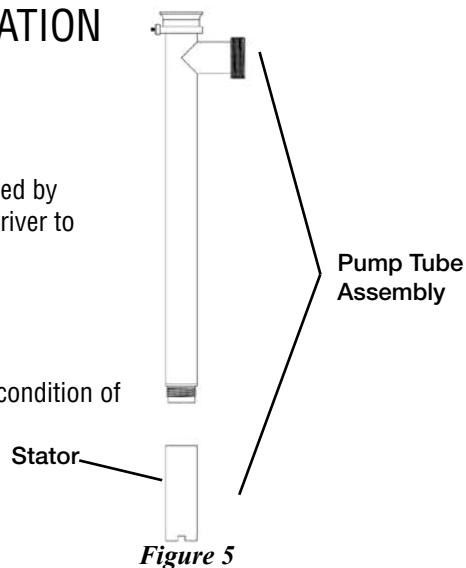

SECTION 4: DRIVE ASSEMBLY REMOVAL & INSTALLATION

REMOVAL:

1. Remove the motor (see section 1 and follow the instructions for your model).
2. Remove stator (see section 2).
3. Remove the bail wire (see Figure 3).
4. Release the cam-lock by pulling the cam-lock levers towards the top of the drive assembly.
5. Pull the drive assembly out of the pump tube assembly while holding the cam-lock levers in the upright position.

INSTALLATION:

1. Make sure that the locating stud on the back of the pump tube assembly is aligned with the drive assembly coupling.
2. Push the drive assembly into the pump tube assembly while holding the cam lock levers in the upright position.
3. Rotate the cam-lock levers downward.
4. Install the bail wire.
5. Install stator.

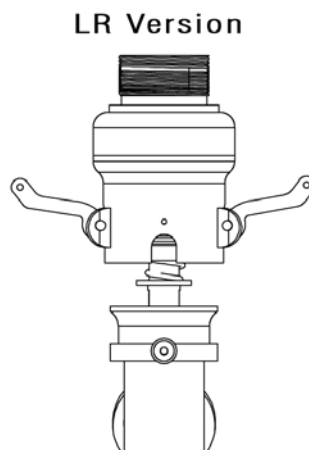
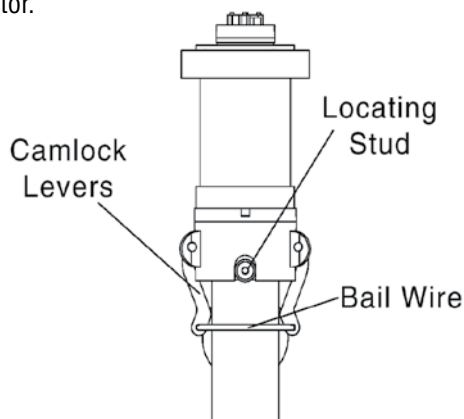

Figure 3

SECTION 5: ROTOR REMOVAL, INSPECTION & INSTALLATION

REMOVAL:

1. Remove the motor (see section 1 and follow the instructions for your model).
2. Remove the drive assembly (see section 3).
3. The rotor is located at the bottom of the drive assembly (see Figure 4).
4. Using 3/4" and 5/8" open-end wrenches, loosen and remove the rotor.

INSPECTION:

1. Inspect the rotor for excessive wear and deep grooving. Contact FTI if you are questioning the condition of the rotor.

INSTALLATION:

1. Reverse the removal instructions found in this section.

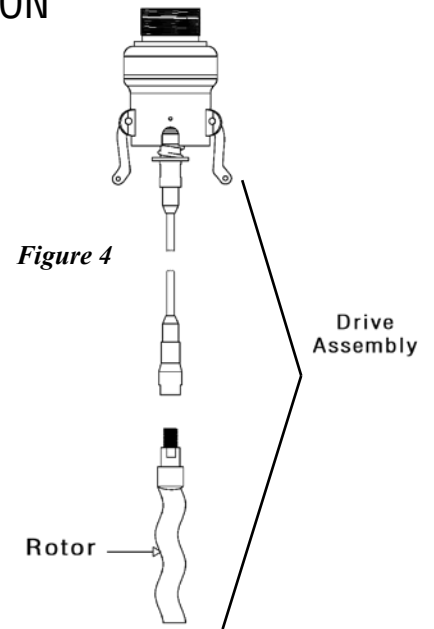

SECTION 6: SEAL REMOVAL, INSPECTION, AND INSTALLATION

REMOVAL:

1. Remove the motor (see section 1 and follow the instructions for your model).
2. Remove stator (see section 2).
3. Remove the drive assembly (see section 3).
4. The seal is located at the interface between the gearbox and the drive shaft (see Figure 6).
5. Secure the pump drive coupling using a pair of pliers.
6. Using a 3/4" open-end wrench, separate the drive shaft from the gearbox.
7. Being sure to protect the polished seal-seating area of the shaft, gently remove the rotating seal boot, spring, and spring retainer.
8. Using a thin bladed screwdriver, remove the stationary component of the seal from the gearbox assembly.

INSPECTION:

1. Inspect the seal for wear and scratching.

INSTALLATION:

1. Lubricate the outside diameter of the stationary seal with a compatible lubricant and carefully install it into the gearbox housing.
2. Install the spring and spring retainer onto the pump shaft.
3. Lubricate the inside of the rotating seal boot with a chemically compatible lubricant and install it onto the pump shaft.
4. Reverse steps five through one of the seal removal instructions found in this section.

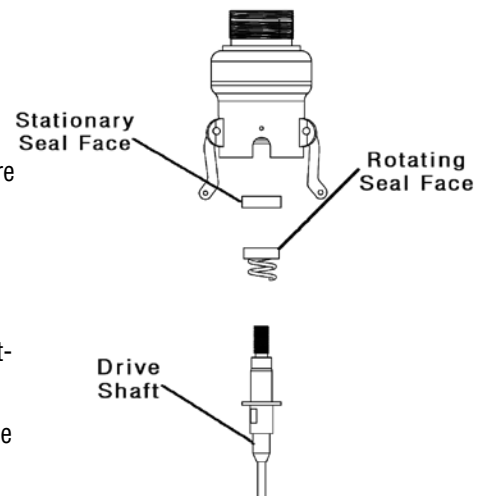
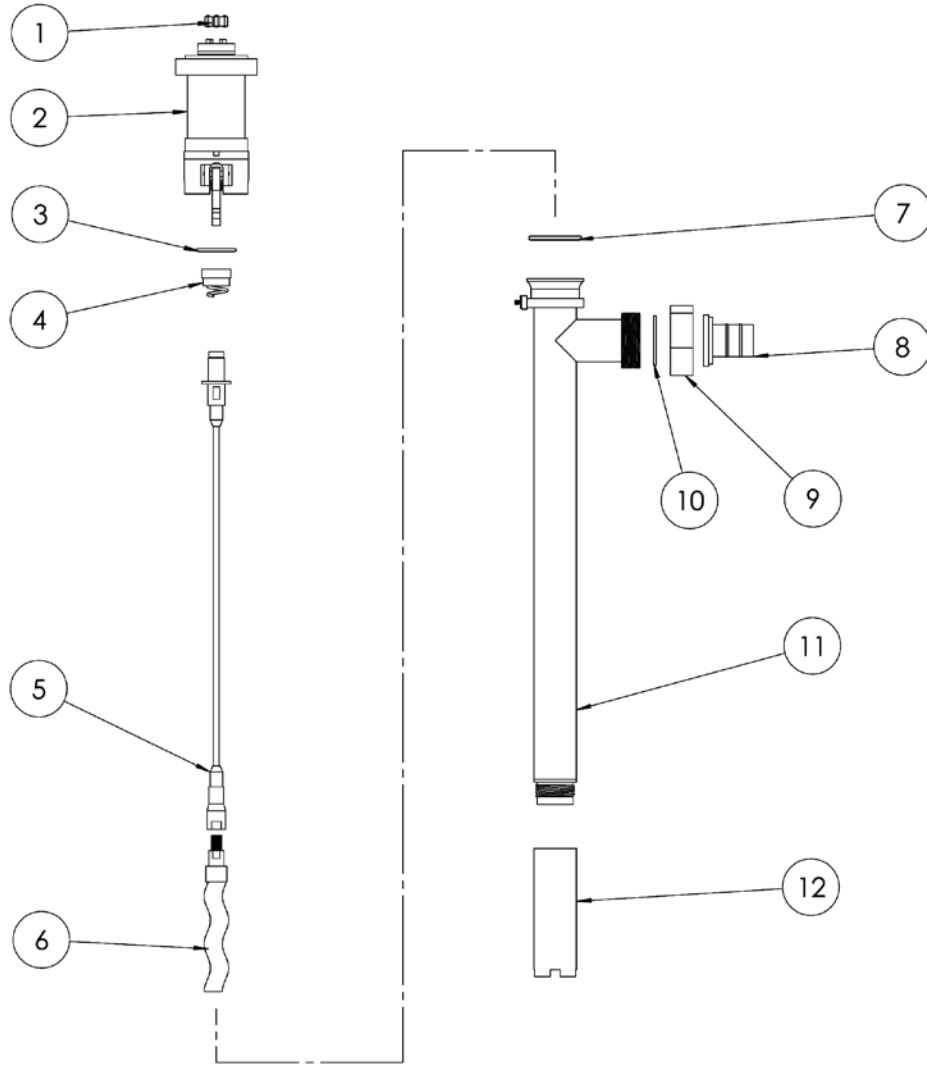

Figure 6

HVDP SERIES - HVDP-HR



ITEM	DESCRIPTION	PART NO.
1	Coupling Insert	J100014
2	HVDP-HR Gear Box Assembly 16:1	105150
3	Tube O-ring FKM	105080
3	Tube O-ring EPDM	105081
3	Tube O-ring Buna-FDA	108069
3	Tube O-ring PTFE Encapsulated Silicone	105082
4	Seal (Carbon/Ceramic/FKM)	J102957-1
4	Seal (Carbon/Ceramic/EPDM)	J102957-2
4	Seal (Carbon/Ceramic/Buna-FDA)	108073
4	Seal (Carbon/Ceramic/Kalrez)	J103081
4	Seal (Silicon Carbide/FKM)	J103066
4	Seal (Silicon Carbide/EPDM)	J103067
5	HVDP 27 HR Shaft Assembly	105146-1
5	HVDP 40 HR Shaft Assembly	105146-2
5	HVDP 48 HR Shaft Assembly	105146-3
6	HVDP Rotor #1	105009-1
6	HVDP Rotor #2	105009-2
6	HVDP Rotor #3	105009-3
7	Coupling O-ring FKM	105083
7	Coupling O-ring EPDM	105084
7	Coupling O-ring Buna-FDA	108071
7	Coupling O-ring PTFE Encapsulated Silicone	105085

ITEM	DESCRIPTION	PART NO.
8	Adapter 1 1/2"	105176
8	HVDP Barbed Hose Adapter 2"	105287
8	HVDP Tri-Clamp Discharge Fitting	107395
9	Union Nut	105023
10	Discharge O-ring FKM	107784
10	Discharge O-ring EPDM	107785
10	Discharge O-ring Buna-FDA	108070
10	Discharge O-ring PTFE Encapsulated Silicone	107786
11	HVDP 27 Intake Tube Assembly*	105143-1
11	HVDP 40 Intake Tube Assembly*	105143-2
11	HVDP 48 Intake Tube Assembly*	105143-3
12	HVDP Buna Stator	105008-1
12	HVDP Buna Stator for Foot Option	105456
12	HVDP FKM Stator	105008-2
12	HVDP FKM Stator for Foot Option	105456-1
12	HVDP PTFE Stator	105326
12	HVDP PTFE Stator for Foot Option	105456-2
-	HVDP Bail Wire Assy (not shown)	105366

*If purchasing or replacing an intake tube, please purchase appropriate o-ring, item 10.

HVDP SERIES - HVDP-LR

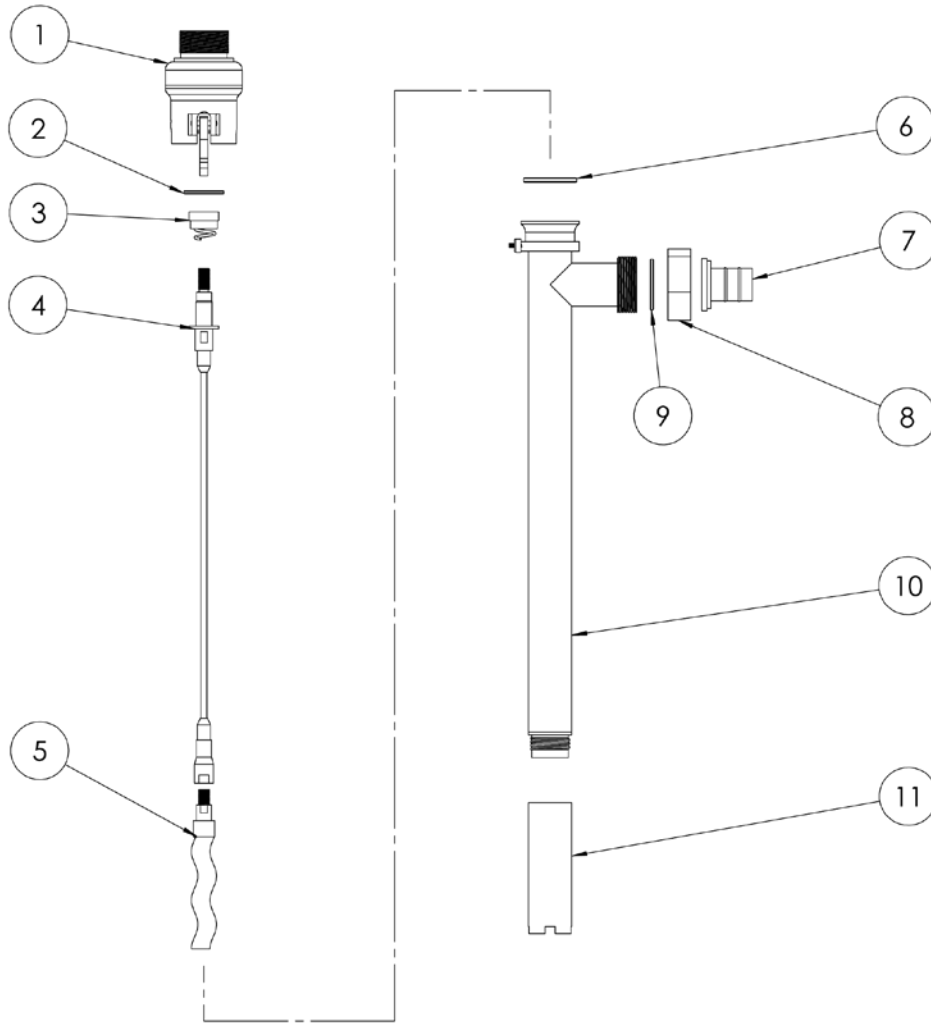

ITEM	DESCRIPTION	PART NO.
1	HVDP LR Gearbox Assembly 5:1	105154
1	HVDP LR Gearbox Assembly 4:1	105155
2	Tube O-ring FKM	105080
2	Tube O-ring EPDM	105081
2	Tube O-ring Buna-FDA	108069
2	Tube O-ring PTFE Encapsulated Silicone	105082
3	Seal (Carbon/Ceramic/FKM)	J102957-1
3	Seal (Carbon/Ceramic/EPDM)	J102957-2
3	Seal (Carbon/Ceramic/Buna-FDA)	108073
3	Seal (Carbon/Ceramic/Kalrez)	J103081
3	Seal (Silicon Carbide/FKM)	J103066
3	Seal (Silicon Carbide/EPDM)	J103067
4	HVDP 27 LR Shaft Assembly	105147-1
4	HVDP 40 LR Shaft Assembly	105147-2
4	HVDP 48 LR Shaft Assembly	105147-3
5	HVDP Rotor #1	105009-1
5	HVDP Rotor #2	105009-2
5	HVDP Rotor #3	105009-3
6	Coupling O-ring FKM	105083
6	Coupling O-ring EPDM	105084
6	Coupling O-ring Buna-FDA	108071
6	Coupling O-ring PTFE Encapsulated Silicone	105085

ITEM	DESCRIPTION	PART NO.
7	HVDP Barbed Hose Adapter 1 1/2"	105176
7	HVDP Barbed Hose Adapter 2"	105287
7	HVDP Tri-Clamp Discharge Fitting	107395
8	Union Nut	105023
9	Discharge O-ring FKM	107784
9	Discharge O-ring EPDM	107785
9	Discharge O-ring Buna-FDA	108070
9	Discharge O-ring PTFE Encapsulated Silicone	107786
10	HVDP 27 Intake Tube Assembly*	105143-1
10	HVDP 40 Intake Tube Assembly*	105143-2
10	HVDP 48 Intake Tube Assembly*	105143-3
11	HVDP Buna Stator	105008-1
11	HVDP Buna Stator for Foot Option	105456
11	HVDP FKM Stator	105008-2
11	HVDP FKM Stator for Foot Option	105456-1
11	HVDP PTFE Stator	105326
11	HVDP PTFE Stator for Foot Option	105456-2
-	HVDP Bail Wire Assy (not shown)	105366

*If purchasing or replacing an intake tube, please purchase appropriate o-ring, item 9.



FINISH THOMPSON INC.

921 Greengarden Road • Erie, PA 16501-1591 U.S.A.
Ph 814-455-4478 • Fax 814-455-8518

Email fti@finishthompson.com • www.finishthompson.com

Service 1-800-888-3743

P/N 105362, Rev. 9, 3/11/2019