



AC6 & AC8 HORIZONTAL SERIES Sealed Metallic Centrifugal Pumps Installation and Maintenance Instructions

ASSEMBLY

PUMPS WITH MOTORS

1. No assembly required. Unpack the pump and motor and examine for any signs of shipping damage. If damage is detected, save the packaging and notify the carrier immediately.
2. Proceed to the "Installation" section of these instructions.

PUMPS WITHOUT MOTORS

Note: Do not remove shipping plug located in suction port of the pump until the pump is completely assembled onto the motor.

1. Unpack the pump and examine for any signs of shipping damage. If damage is detected, save the packaging and notify the carrier immediately.

Special Note: AC6HJS 90 frame only -

- a. Using the hardware provided (items 9, 10, & 11), bolt the motor adapter (item 8) to the motor.
 - b. Attach the mounting plate (item 14) to the motor adapter using the hardware provided (items 12 & 13).
 - c. Proceed to page 2 of the Installation and Maintenance Manual and follow steps 1 through 9 under "Reassembly."
2. Insert key into motor keyway. Visually determine key location in pump end. Align keyway slots on motor shaft and pump impeller sleeve. Slide pump assembly over the motor shaft until the pump motor adapter (item 8) is completely seated over the motor rabbet. The drain slot should always be on the bottom. Install 4 bolts with flat washers and lock washers (items 9,10,11) into the motor face. Securely tighten bolts.
 3. Lubricate o-ring of self-sealing bolt (item 6) with suitable, compatible lubricant. Insert self-sealing bolt through shipping plug and into the eye of the impeller using a 9/16" deep well socket. Insert a screwdriver into the motor fan to prevent motor shaft from rotating. Tighten the bolt to 12-ft lbs.
 4. Remove the shipping plug from the suction port.
 5. Rotate the motor fan by hand and check for impeller rubbing. If the impeller rubs, verify that the self-sealing bolt is properly installed.
 6. Proceed to the "Installation" section of these instructions.

INSTALLATION

MOUNTING

Motor or base plate must be securely fastened.

PIPING TO AND FROM THE PUMP:

- Always support the piping near the pump to minimize stress and strain on the pump's casing.

- Minimize frictional losses by increasing the suction piping size by one diameter.
- Use a minimal number of bends on suction piping, keeping any bends a minimum of ten pipe diameters from the pump.
- Install a shut off valve on the suction line and a flow control valve in the discharge line. Place the valves a minimum of ten pipe diameters from the pump.
- Ensure that the piping is leak free.
- Position the pump as close to the liquid source as possible.
- Maintain a flooded suction at all times or prime the pump and maintain prime at all times.

CAUTION: Do not run the pump dry. This pump should never be started without liquid in the casing.

The fluid being transferred by the pump lubricates the pump components. Even short periods of running the pump dry could damage the pump. It is recommended that run dry protection be used.

Optional electronic power monitors are available to help protect against run dry.

PUMPING LIQUIDS THAT MAY SOLIDIFY OR CRYSTALLIZE

Add a flush system to the pump's piping to prevent accumulation of material inside the pump. Install water inlet and outlet valves as shown in Figure 1. Refer to the "Operation" section of these instructions for the flush procedure.

Figure 1

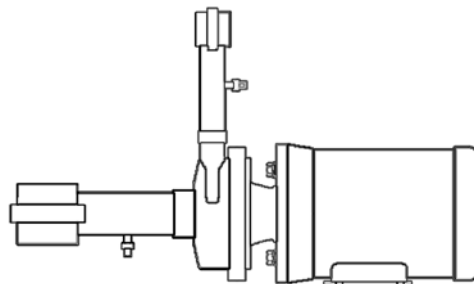

MOTOR/ELECTRICAL

Only qualified personnel trained in the safe installation and operation of this equipment should install the motor. Install the motor according to National Electric Code, NEMA MG-2, IEC standards requirements and/or applicable local electrical codes. The voltage and frequency variations of the power supply should never exceed the limits established in the applicable standard. Prior to connecting to the power line, check nameplate voltage, rotation connection and ensure proper grounding. Sufficient ventilation area should be provided to insure proper operation and cooling of the motor. The motor must be installed with a suitable overload

protection circuit. For three phase motors it is recommended to install a phase failure protection device. Download the motor manual from the specific motor manufacturers' website for additional information concerning motor installation, safety and maintenance instructions.

Wire the motor for clockwise rotation when facing the fan end of the motor.

CAUTION: Do not operate the pump to check rotation until the pump is full of liquid or damage may occur even if the motor is "bumped" to check motor rotation direction.

Check all electrical connections with the wiring diagram on the motor. Make sure the voltage, frequency, phase and amp draw comply with the supply circuit.

If utilized, verify that power monitors or variable frequency drives have been properly installed according to the manufacturer's instructions.

NOTE: A pump running backwards will pump but at a greatly reduced flow and pressure.

OPERATION

FLOODED SUCTION SYSTEMS:

1. Fully open the suction and discharge valves.
2. Start the pump and verify liquid is flowing. If there is no liquid flow, refer to the "Troubleshooting" section of these instructions.
3. Adjust the flow rate and pressure by regulating the discharge valve.

CAUTION: Never use the suction valve to adjust the liquid flow. Limiting the suction will result in damage to pump components.

FLUSHING SYSTEMS EQUIPPED WITH FLUSH VALVES

1. Fully close the suction and discharge valves.
2. Connect the water supply to the water inlet valve and connect a drain hose to water outlet valve.
3. Turn on the water supply and open the inlet and outlet valves. Flush the system until the pump has been cleared of any material buildup (usually approximately 5 minutes).
4. Close the water inlet and outlet valves and turn off water supply.

MAINTENANCE

SEAL REPLACEMENT DISASSEMBLY

1. Disconnect power. Remove electrical wiring.
2. Close the suction and the discharge valves. Disconnect the piping. Remove any mounting bolts.
3. For AC6 pumps - To remove the v-clamp (item 2) and the impeller housing (item 1), first apply a thread lubricant to the threaded rod portion of the v-clamp, then remove the nut. Remove the v-clamp, the housing, and the o-ring (item 3).

For AC8 pumps - Remove the 8 housing bolts and all the hardware (items 15,16,17, 18). Remove the impeller housing (item 1) and the o-ring (item 3).

4. Place a screwdriver in the motor fan to prevent rotation and remove the self-sealing bolt (item 6).

Note: Do not reuse the self-sealing bolt.

5. Remove impeller (item 4), rotating seal component, seal spring and seal spring retainer. Discard seal components after removal. (See Figure 2).

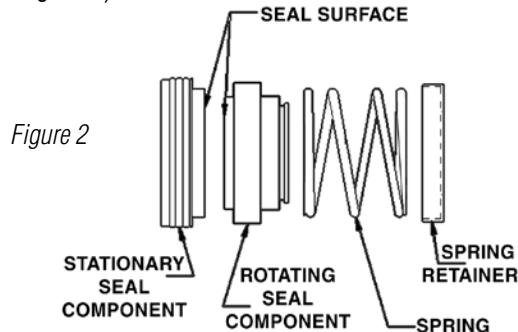

6. Remove backhead assembly (item 7) and press out the stationary seal component. Discard stationary seal component after removal.

REASSEMBLY

1. Lubricate the rubber portion of the new stationary seal (item 5) with P-80 (or equivalent) or use soapy water. Do not use petroleum products to lubricate the rubber.

Note: Keep the polished surface of the seal face clean. Use a piece of cardboard to protect the seal while pressing against the stationary face.

2. Press the stationary seal into the seal seat of the backhead assembly so that the seal surface points away from the motor face. Place backhead into motor adapter.
3. Place the spring retainer and seal spring onto the impeller sleeve.
4. Lubricate the inside diameter of the rotating seal component with P-80 (or equivalent) or soapy water and press it over the impeller sleeve (item 4) with the rotating face pointed away from the impeller as shown in Figure 2 (towards the stationary face).
5. Insert key into the motor keyway. Visually determine key location in impeller sleeve. Align keyway slots on motor shaft and impeller sleeve. Slide impeller assembly over the motor shaft. Lubricate o-ring of new self-sealing bolt (item 6) with suitable, compatible lubricant. Insert self-sealing bolt into the eye of the impeller using a 9/16" deep well socket. Insert a screwdriver into the motor fan to prevent motor shaft from rotating. Tighten the bolt to 12-ft lbs.

6. Place impeller housing (item 1) over backhead (item 7) and o-ring (item 3) and make sure discharge is in the correct orientation (usually 12 o'clock).

NOTE: Stainless Steel hardware can gall, be damaged and become very difficult to remove. To prevent galling use a lubricant like Loctite Anti-Seize or some other compatible lubricant or coating material, use a slow RPM speed to tighten and immediately stop tightening if galling is noticed. If galled remove & replace the hardware.

7. For AC6 pumps – Place the v-clamp (item 2) over the impeller housing, backhead, and the mounting plate (item 14). Make sure the discharge is level and in the correct orientation (see Figure 3). Tighten the nut on the v-clamp. Firmly tap the v-clamp with a mallet in several spots, and then retighten the nut.

For AC8 pumps- Insert the mounting bolts with flat washer (items 15 &16) through the impeller housing (item 1), the backhead (item 7), and the mounting plate (item 14), and tighten with the correct hardware (items 15,17, and 18).

8. Rotate the motor fan by hand and check for impeller rubbing. If the impeller rubs, verify that the self-sealing bolt is properly installed.
9. Reinstall the pump into the system.

Figure 3

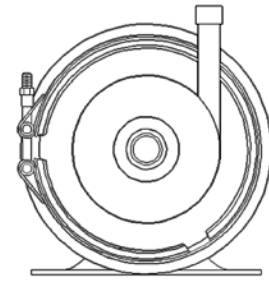

AC 6 EXPLODED VIEW

See pages 4-5 for parts matrix.

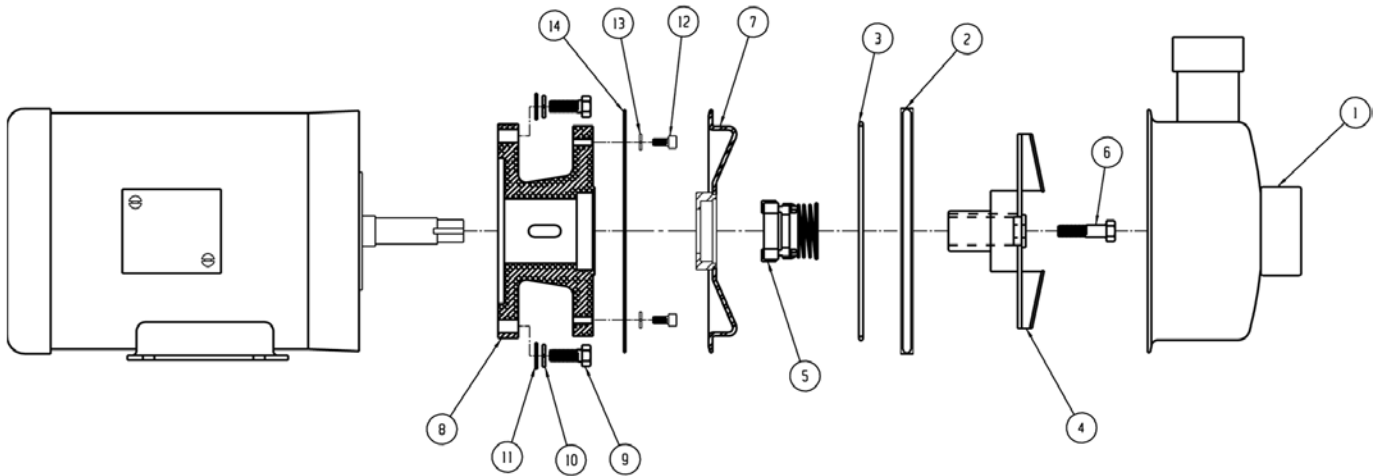

AC 8 EXPLODED VIEW

See pages 6-7 for parts matrix.

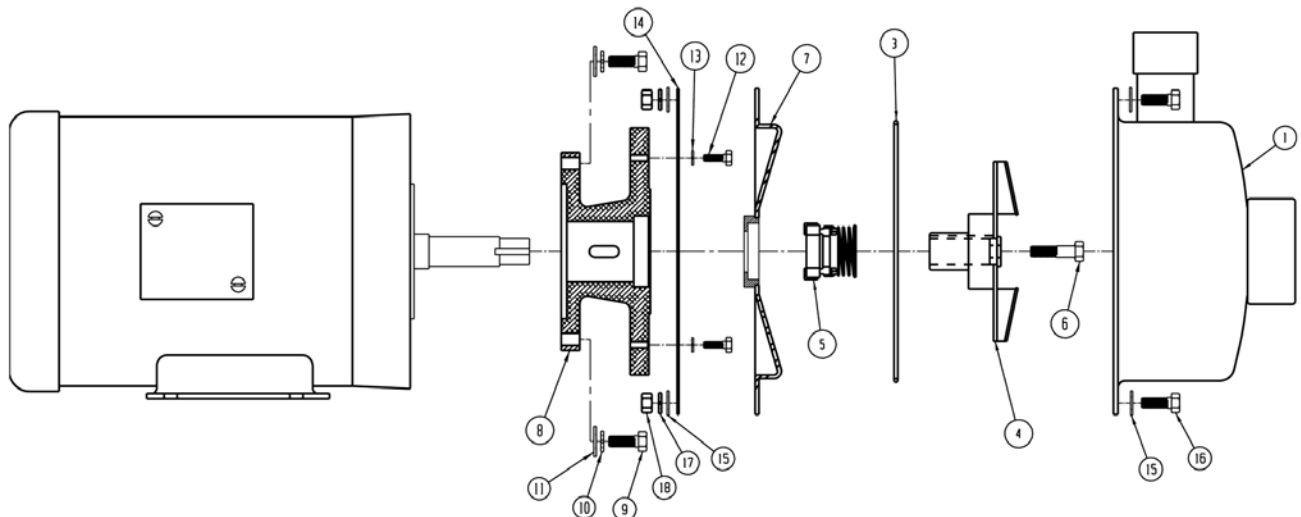

AC6 & AC6H Spare Parts

Item	Description	Part Number
1	Impeller Housing	
	AC6SJS1 - 1-1/2" x 1-1/4" FNPT	A102184-1
	AC6SJS2 - 2" x 1-1/2" FNPT	A102184-2
	AC6SJS3 - 1-1/2" x 1-1/4" FBSP	A102184-3
	AC6SJS4 - 2 x 1-1/2" FBSP	A102184-4
	AC6SJS5 - 2 x 1-1/2" ANSI 150# dimensional flanges	108921
	AC6SJS6 - 1-1/2" x 1-1/4" ANSI 150# dimensional flanges	108504
	AC6SJS7 - 2" x 2" ANSI 150# dimensional flanges	108505
	AC6SJS8 - 1-1/2" x 1-1/2" electropolished tri-clamp fittings	108477
	AC6SJS9 - 2-1/2" x 1-1/2" electropolished tri-clamp fittings	108506
	AC6HJS1 - 1-1/4" x 3/4" high head FNPT	A102232
	AC6HJS2 - 1-1/4" x 3/4" high head FBSP	A102232-1
	AC6HJS3 - 1-1/2" x 1" high head electropolished tri-clamp fittings	108507
2	V Clamp	
	304 stainless steel	J103090
3	Housing O-Ring	
	FKM	J103084
	EPDM	J103085
	PTFE encapsulated silicone	J103257
	Buna (FDA compliant)	108402
4	Impeller 316 Stainless Steel	
	520 - 5.25" x 1/4" standard (AC6SJS)	A102734-6
	570 - 5.75" x 1/4" standard (AC6SJS)	A102734-7
	600 - 6.00" x 1/4" standard (AC6SJS)	A102734-8
	520 - 5.25" x 1/4" standard (AC6SJS) electropolished	108447-6
	570 - 5.75" x 1/4" standard (AC6SJS) electropolished	108447-7
	600 - 6.00" x 1/4" standard (AC6SJS) electropolished	108447-8
	620 - 6.25" x 3/16" high head (AC6HJS)	A102735-1
	620 - 6.25" x 3/16" high head (AC6HJS) electropolished	108448-1
5	Mechanical Seal	
	Carbon/Ceramic/FKM (B01)	J103493
	Carbon/Ceramic/EPDM (B02)	J103500
	Silicon Carbide/Silicon Carbide/FKM (B03)	J103501
	Silicon Carbide/Silicon Carbide/EPDM (B04)	J103502
	Carbon/Ceramic/Kalrez® (B05)	J103503
	Carbon/Ceramic/Buna (B07)	108413
6	Impeller Bolt	
	with FKM for AC6SJS	J103495
	with EPDM for AC6SJS	J103499
	with Buna for AC6SJS (FDA compliant)	108406
	with PTFE for AC6SJS	J102823
	with FKM for AC6HJS	J103494
	with EPDM for AC6HJS	J103498
	with Buna for AC6HJS (FDA compliant)	108405
	with PTFE for AC6HJS	J103582

AC6 & AC6H Spare Parts cont.

7	Backhead	
	316 stainless steel	A102677-1
	316 stainless steel electropolished	108450
8	Cast Iron Motor Adapter	
	AC6SJS	M102051-4
	AC6HJS	M102051-5
9	Cap Screw (4 req'd.)	
	3/8-16 x 1-1/4" stainless steel hex head	J103118
10	Lock Washer (4 req'd.)	
	3/8" stainless steel	J100115
11	Flat Washer	
	3/8" stainless steel	J100128
12	Cap Screw (4 req'd.)	
	1/4-20 x 1/2" stainless steel socket head	J103396
13	Lock Washer (4 req'd.)	
	1/4" stainless steel	J100115
14	Mounting Plate	
	Stainless steel	J103389-2

AC8 & AC8H Spare Parts		
Item	Description	Part Number
1	Impeller Housing	
	AC8SJS1 - 2" x 1-1/2" FNPT	A102747-1
	AC8SJS4 - 2" x 1-1/2" FBSP	A102747-4
	AC8SJS5 - 2-1/2" x 2" ANSI 150# dimensional flanges	108918
	AC8SJS6 - 2" x 1-1/2" ANSI 150# dimensional flanges	108916
	AC8SJS7 - 2" x 2" ANSI 150# dimensional flanges	108508
	AC8SJS8 - 2-1/2" X 1-1/2" ANSI 150# dimensional flanges	108917
	AC8SJS9 - 2-1/2" x 1-1/2" electropolished tri-clamp fittings	108528
	AC8SJS10 - 2-1/2" x 2" electropolished tri-clamp fittings	108511
	AC8SJS2 - 2-1/2" x 2" FNPT (high flow)	A102747-2
	AC8SJS3 - 2-1/2" x 2" FBSP (high flow)	A102747-3
	AC8SJS11 - 3" x 2" ANSI 150# dimensional flanges (high flow)	108509
	AC8SJS12 - 3" x 3" ANSI 150# dimensional flanges (high flow)	108510
	AC8SJS13 - 3" x 2-1/2" electropolished tri-clamp fittings (high flow)	108512
	AC8HJS1 - 1-1/4" x 3/4" high head FNPT	A102528
	AC8HJS2 - 1-1/4" x 3/4" high head FBSP	A102528-1
	AC8HJS3 - 2" x 1" high head electropolished tri-clamp fittings	108513
3	Housing O-Ring	
	FKM	J103087
	EPDM	J103088
	PTFE encapsulated silicone	J103258
	Buna (FDA compliant)	108403
4	Impeller 316 Stainless Steel	
	650 - 6.50" x 1/4" standard (AC8SJS)	A102734-1
	700 - 7.00" x 1/4" standard (AC8SJS)	A102734-2
	750 - 7.50" x 1/4" standard (AC8SJS)	A102734-3
	800 - 8.00" x 1/4" standard (AC8SJS)	A102734-9
	650 - 6.50" x 1/4" standard (AC8SJS) electropolished	108447-1
	700 - 7.00" x 1/4" standard (AC8SJS) electropolished	108447-2
	750 - 7.50" x 1/4" standard (AC8SJS) electropolished	108447-3
	800 - 8.00" x 1/4" standard (AC8SJS) electropolished	108447-9
	658 - 6.50" x 3/8" standard (AC8SJS high flow)	A102734-4
	708 - 7.00" x 3/8" standard (AC8SJS high flow)	A102734-5
	658 - 6.50" x 3/8" standard (AC8SJS high flow) electropolished	108447-4
	708 - 7.00" x 3/8" standard (AC8SJS high flow) electropolished	108447-5
	620 - 6.25" x 3/16" high head (AC8HJS)	A102735-1
	670 - 6.75" x 3/16" high head (AC8HJS)	A102735-8
	700 - 7.00" x 3/16" high head (AC8HJS)	A102735-2
	800 - 8.00" x 3/16" high head (AC8HJS)	A102735-3
	620 - 6.25" x 3/16" high head (AC8HJS) electropolished	108448-1
	670 - 6.75" x 3/16" high head (AC8HJS) electropolished	108448-4
	700 - 7.00" x 3/16" high head (AC8HJS) electropolished	108448-2
800 - 8.00" x 3/16" high head (AC8HJS) electropolished	108448-3	

AC8 & AC8H Spare Parts cont.

5	Mechanical Seal	
	Carbon/Ceramic/FKM (B01)	J103493
	Carbon/Ceramic/EPDM (B02)	J103500
	Silicon Carbide/Silicon Carbide/FKM (B03)	J103501
	Silicon Carbide/Silicon Carbide/EPDM (B04)	J103502
	Carbon/Ceramic/Kalrez® (B05)	J103503
	Carbon/Ceramic/Buna (B07)	108413
6	Impeller Bolt	
	With FKM for AC8SJS	J103495
	With EPDM for AC8SJS	J103499
	with Buna for AC8SJS (FDA compliant)	108406
	With PTFE for AC8SJS	J102823
	With FKM for AC8HJS	J103494
	With EPDM for AC8HJS	J103498
	with Buna for AC8HJS (FDA compliant)	108405
	With PTFE for AC8HJS	J103582
7	Backhead	
	316 stainless steel	A102677-2
	316 stainless steel electropolished	108451
8	Cast Iron Motor Adapter	
	AC8HJS 143-184JM	M102051-3
	AC8SJS 143-184JM	M102051-1
	AC8SJS 213-215JM	M102051-2
8A	Motor Adapter Flange	
	213-215JM frame - 316 stainless steel	106144
9	Cap Screw (4 req'd.)	
	3/8-16 x 1-1/4" stainless steel hex head - 143-184JM	J103118
	1/2-13 x 1-1/2" stainless steel hex head - 213-215JM	J101858
10	Lock Washer (4 req'd.)	
	3/8" stainless steel - 143-184JM	J100115
	1/2" stainless steel - 213-215JM	J101023
11	Flat Washer	
	3/8" stainless steel - 143-184JM	J100128
	1/2" stainless steel - 213-215JM	J101360
12	Cap Screw (8 req'd.)	
	1/4" stainless steel socket head	J100320
13	Lock Washer (8 req'd.)	
	1/4-20 x 3/4" stainless steel	J100672
14	Mounting Plate	
	Stainless steel	J103857
15	Flat Washer (16 req'd.)	
	3/8" stainless steel	J100128
16	Cap Screw (8 req'd.)	
	3/8-16 x 1" stainless steel hex head	J100114
17	Lock Washer (8 req'd.)	
	3/8" stainless steel	J100115
18	Nut (8 req'd.)	
	3/8" stainless steel hex	J100135

TROUBLESHOOTING

NO OR INSUFFICIENT FLOW:

1. Pump not primed.
2. Closed valve.
3. Viscosity too high.
4. Air leaks in suction piping.
5. Discharge head higher than anticipated.
6. Suction lift too high or insufficient NPSH.
7. Check for clogged suction line.

INSUFFICIENT PRESSURE:

1. Air or gas in liquid.
2. Impeller diameter too small.
3. Discharge head higher than anticipated.
4. Motor speed insufficient (too low) or rotation incorrect.

LOSS OF PRIME:

1. Leaking suction line.
2. Foot valve or suction opening not submerged enough.
3. Foot valve too small or leaking.
4. Air or gas in liquid.
5. Foreign matter in impeller.

EXCESSIVE POWER CONSUMPTION:

1. Head lower than rating. Excessive flow.
2. Specific gravity or viscosity of liquid is too high.

EXCESSIVE VIBRATION:

1. Loose piping or bolts.
2. Pump cavitating from improper suction or feed.

SAFETY PRECAUTIONS FOR ATEX PUMPS

⚠ WARNING: Proper materials of construction must be chosen for the fluid being pumped. Improper material selection could lead to pump failure and leakage. This is the responsibility of the end user.

⚠ WARNING: ATEX pumps must have a power monitor, flow switch, pressure switch or similar device installed to protect against running dry, closed discharge valve, major leaks, and possible sources of ignition due to motor bearing failure. Any of these conditions could lead to a rise in surface temperature of the pump. The device must be set to stop the pump within three seconds of a fault.

⚠ WARNING: The pump must be checked for leaks on a regular basis. If leaks are detected, the pump must be repaired or replaced immediately.

⚠ WARNING: The pump must be cleaned on a regular basis to avoid dust buildup greater than 5mm.

TEMPERATURE CLASSIFICATION

Pump temperature is completely dependent on operating conditions. Pump will transfer heat from the piping system, motor, and fluid. These items must be considered as a system when assessing an ATEX application.

WARRANTY

Finish Thompson, Inc (manufacturer) warrants this pump product to be free of defects in materials and workmanship for a period of one year from date of purchase by original purchaser. If a warranted defect, which is determined by manufacturer's inspection, occurs within this period, it will be repaired or replaced at the manufacturer's option, provided (1) the product is submitted with proof of purchase date and (2) transportation charges are prepaid to the manufacturer. Liability under this warranty is expressly limited to repairing or replacing the product or parts thereof and is in lieu of any other warranties, either expressed or implied. This warranty does not apply to normal wear of the product or components. This warranty does not apply to products or parts broken due to, in whole or in part, accident, overload, abuse, chemical attack, tampering, or alteration. The warranty does not apply to any other equipment used or purchased in combination with this product. The manufacturer accepts no responsibility for product damage or personal injuries sustained when the product is modified in any way. If this warranty does not apply, the purchaser shall bear all cost for labor, material and transportation.

Manufacturer shall not be liable for incidental or consequential damages including, but not limited to process down time, transportation costs, costs associated with replacement or substitution products, labor costs, product installation or removal costs, or loss of profit. In any and all events, manufacturer's liability shall not exceed the purchase price of the product and/or accessories.

WARRANTY REGISTRATION

Thank you for your purchase of this quality Finish Thompson product. Be sure to take a minute to register your pump at Finishthompson.com/warranty. Simply provide the model number, serial number and a few other pieces of information.

Call our toll free Technical Service Hot Line, 1-800-888-3743, if you have any questions regarding product operation or repair.

For further information, contact Finish Thompson Inc. or your local distributor.

ADDITIONAL INFORMATION

ORDERING SPARE PARTS:

Spare parts can be ordered from your local distributor. Always refer to pump model number to avoid error.

OTHER FTI PRODUCTS:

Drum Transfer Pumps are available in sanitary construction, stainless steel, polypropylene and CPVC. Flows to 40 gpm, discharge heads to 80 feet and viscosities to 15,000 cps.

Portable Mixers for turbine mixing and blending handle viscosities to 1,000 cps with gentle, non-vortex circulation. Available in 316 stainless steel construction.

Sealed Centrifugal Pumps in GF polypropylene and CF PVDF come with a wide variety of sealing materials. Flows to 250 gpm, discharge heads to 130 feet and temperatures to 200°F (93°C).

Sealless Mag Drive Centrifugal Pumps in GF polypropylene and CF PVDF. Flows to 250 gpm and discharge heads to 135 feet. Handles temperatures up to 220°F and have 30-minute run-dry capability. Mounts to standard frame motors.



FINISH THOMPSON INC.

921 Greengarden Road • Erie, PA 16501-1591 U.S.A.
Ph 814-455-4478 • Fax 814-455-8518
Email ft@finishthompson.com • www.finishthompson.com

EU Declaration of Conformity



Finish Thompson Inc. hereby declares that the following machine(s) fully comply with the applicable health and safety requirements as specified by the EU Directives listed. The product may not be taken into service until it has been established that the drive motor for the centrifugal pump complies with the provisions of all relevant EU Directives. The complete product complies with the provisions of the EC Directive on machinery safety provided motors carry CE marking.

This declaration is valid provided that the devices are fully assembled and no modifications are made to these devices.

Type of Device:

Centrifugal Pumps

Models:

AC/AK/AV - 400/500/600/800	GP-11/22/32	VKC-5.5/6/6H/7/8/10
DB-3/4/5/5.5/6/6H/7/8/9/10/11/15/22	MSKC	SP-10/11/15/22
KC-3/4/5/5.5/6/6H/8/10/11/22/32	MSVKC	
UC-1516/1516L/1518/1518L/2110/3158/326/326H/328/436/438/4310H/326H/4310H/6410		

EU Directives:

Machinery Safety (2006/42/EC)

Applied Harmonized Standards:

EN ISO 12100
EN 809

Manufacturer: Finish
Thompson Inc.
921 Greengarden Road
Erie, Pennsylvania 16501-1591 U.S.A

Signed,

President

1 August 2016

Person(s) Authorized to Compile Technical File: Finish Thompson GmbH
Otto-Hahn-Strasse 16
Maintal, D-63477 DEU
Telephone: 49 (0)6181-90878-0

EU Declaration of Conformity

Manufactured by:

Finish Thompson, Inc.
921 Greengarden Road
Erie, Pennsylvania 16501 U.S.A.
Phone: 1-(814)-455-4478
Fax 1-(814)-455-8518
Email: fti@finishthompson.com
Web: www.finishthompson.com



FINISH THOMPSON INC.



1026

II 2GD
Ex h IIC TX Gb
Ex h IIIC TX Db
FTZU 05 A127-05

This declaration applies to Finish Thompson **AC Series pumps**.

Finish Thompson declares under our sole responsibility that the product listed above conforms to the relevant provisions of EU directive **2014/34/EU of 26 February 2014** for equipment and protective systems intended for use in potentially explosive atmospheres, and is certified for safe use in **Atmosphere Group IIC/IIIC category 2 areas**.

This product has used the following harmonized standards to verify conformance:

Non-electrical equipment for potentially explosive atmospheres: **EN ISO 80079-36:2016**
Basic Methods and Requirements.

Non-electrical equipment intended for use in potentially explosive atmospheres: **EN ISO 80079-37:2016**
Protection by construction safety "ch." and control of ignition source "bh"

This product must not be used in areas other than specified above. If in doubt consult an authorized distributor, or refer to the manufacturer Finish Thompson.

Approved by:

Date: 5/5/2017



FINISH THOMPSON INC.

921 Greengarden Road • Erie, PA 16501-1591 U.S.A.
Ph 814-455-4478 • Fax 814-455-8518

Email fti@finishthompson.com • www.finishthompson.com

Part No. J103532, Rev. 12, 4/5/2019

