

MV Series Motors Operation & Parts Manual

Models M3V, M5V, M5V-US



FINISH THOMPSON INC.

921 Greengarden Road • Erie, PA 16501-1591 U.S.A.

Ph 814-455-4478 • Fax 814-455-8518

Email fti@finishthompson.com • www.finishthompson.com



FINISH THOMPSON INC.

921 Greengarden Road • Erie, PA 16501-1591 U.S.A.
Ph 814-455-4478 • Fax 814-455-8518
Email fti@finishthompson.com • www.finishthompson.com

EU Declaration of Conformity



Finish Thompson Inc. hereby declares that the following electrical equipment fully complies with the applicable health and safety requirements as specified by the EC Directives listed. The product may not be taken into service until it has been established that the driven Drum and Container Pump complies with the provisions of all relevant EC Directives. The complete product complies with the provisions of the EC Directive on machinery safety provided pumps manufactured by Finish Thompson Inc. are used.

This declaration is valid provided that the devices are fully assembled and no modifications are made to these devices.

Type of Device:

Electric Motors for Driving Drum
and Container Pumps

Models:

M3V-UK	M5	M5T M59P	M5V M59H	M5X S2	M13 S3	M54	M56
--------	----	-------------	-------------	-----------	-----------	-----	-----

EC Directives:

Low Voltage Equipment (98/37/EC)
Electromagnetic Compatibility (2004/108/EC)

Applied Harmonized Standards:

EN 60335-1 EN 60335-2-41
EN 55014-1 EN 55014-2
EN 60529

Manufacturer:
Finish Thompson Inc.
921 Greengarden Road
Erie, Pennsylvania 16501-1591 U.S.A

Signed,

President

December 29, 2009

Introduction

This manual pertains to drum pump motors MV Series. Finish Thompson, Inc. thanks you for choosing our products. We believe the use of our products will be fully satisfactory. When properly installed and operated, your Finish Thompson motor and pump will provide long, trouble-free service; therefore please read this manual carefully before carrying out any operations on the pump-motor unit. Any use other than that described herein is considered incorrect and; consequently, Finish Thompson, Inc. shall not be held responsible for any damages to people or things. In case of doubt or enquiries, please apply to our Technical Service department directly at the following address:

Finish Thompson, Inc.
921 Greengarden Rd.
Erie, PA 16501 U.S.A.
Tel. 1-814-455-4478
Fax 1-814-455-8518
www.finishthompson.com
fti@finishthompson.com

Index

Introduction	1
General Terms & Conditions, Warranty	2
Safety	3
Installation	4
Operation, Specifications & Identification	5
Parts	6

WARRANTY, GENERAL TERMS & CONDITIONS

1. The following terms and condition apply to the sale of machinery, components and related services and products, of Finish Thompson Inc. (hereinafter “the products”).
2. Finish Thompson Inc. (the manufacturer) warrants only that:
 - a.) its products are free of defects in material, design and workmanship at the time of original purchase
 - b.) its products will function in accordance with Finish Thompson Inc. operation manuals; Finish Thompson Inc. does not guarantee that the product will meet the precise needs of the Customer, except for those purposes set out in any invitation to render documents or other documents specifically made available to Finish Thompson, Inc. before entering into this agreement
 - c.) high quality materials are used in the construction of the pumps and that machining and assembly are carried out to the highest standards. Except as expressly stated above, Finish Thompson, Inc. makes no warranties, express or implied, concerning the products, including all warranties of fitness for a particular purpose.
3. This warranty shall not be applicable in circumstances other than defects in material, design, and workmanship. In particular, this warranty shall not cover the following:
 - a.) Periodic checks, maintenance, repair and replacement of parts due to normal wear and tear;
 - b.) Damage to the product resulting from:
 - i. tampering with, abuse or misuse, including but not limited to failure to use the product for its normal purposes as stated at the time of purchase or in accordance with Finish Thompson, Inc. instructions for use and maintenance of the product, or the installation or improper ventilation or use of the product in a manner inconsistent with the technical or safety standard in force
 - ii. repairs performed by non-authorized service workshop, or opening of the unit by nonauthorized personnel, or use of non genuine Finish Thompson, Inc. parts
 - iii. accidents, acts of God or any cause beyond the control of Finish Thompson, Inc., including but not limited to lightning, water, fire, earthquake, and public disturbances, etc.
4. This warranty shall cover the replacement or repair of any part(s), which is documented to be faulty due to construction or assembling, with a new or repaired part(s) free of charges delivered by Finish Thompson, Inc. Part(s) subjected to normal tear and wear shall not be covered by the warranty. Finish Thompson, Inc. shall decide as to whether the defective or faulty part shall be replaced or repaired. Transportation charge is prepaid to Finish Thompson.
5. The warranty of the products shall be valid for a period of 12 months from the date of delivery, under the condition that notice of the alleged defect to the product(s) or part(s) thereof be given to Finish Thompson Inc. in writing within the term of 8 days from the discovery.
6. Repair or replacement under the terms of the warranty shall not give a right to an extension to, or a new commencement of, the period of warranty. Repair or replacement under the terms of this warranty may be fulfilled with functionally equivalent, reconditioned units. Finish Thompson Inc. qualified personnel shall be solely entitled to carry out repair or replacement of faulty parts after careful examination of the motor. Faulty parts or components when replaced by Finish Thompson Inc. will become the property of Finish Thompson Inc. If this warranty does not apply, the purchaser shall bear all cost for labor, material and transportation.
7. Finish Thompson Inc. will not be liable on any claim, whether in contract, tort, or otherwise, for any indirect, special, incidental, or consequential damages, caused to the customer or to third parties, including loss of profits, process down time, transportation costs, costs associated with replacement or substitution products, labor costs, installation or removal costs. In any and all events, manufacturer’s liability shall not exceed the purchase price of the product and/or accessories.
8. Return Policy. Should you have any problems with this product, please contact the distributor in your area. The distributor will determine if a return to the factory is necessary and will contact the factory for a Return Authorization Number. Otherwise, contact our Technical Service Hotline (1-800-888-3743) or email techservice@finishthompson.com if you have any questions regarding product operation or repair.

SAFETY

1. Introduction

This manual contains all the information needed for the correct installation, use and maintenance of your new Finish Thompson motor. It should be read and understood by all the personnel involved in installation, operating and servicing of the pump before it is started.

2. Operator Qualification and Training

The personnel in charge of the installation, operation and maintenance of the pump unit we produce must be qualified and able to perform the operations described in this manual. Finish Thompson Inc. shall not be held responsible for the training level of personnel and for the fact that they are not fully aware of the contents of this manual.

3. Safety Instructions



FOR YOUR OWN SAFETY:

BEFORE UNDERTAKING ANY SERVICE OPERATION ON YOUR MOTOR OR PUMP, PLEASE MAKE SURE TO WEAR THE PROPER PROTECTIVE GEAR.



GENERAL DANGER

NEVER use a plastic pump or an open, splash-proof, TEFC or non-ATEX motor when pumping or mixing flammable or combustible material.

ALWAYS use and store the pump and motor in an upright position.



DANGER: POWER SUPPLY

NEVER perform any maintenance operation on the motor while it is running or before it has been disconnected from the power supply. Avoid any possible hazard that might be caused by electric power.

ALWAYS check the electrical specifications on the motor data plate and make sure they correspond to the power supply to which it will be connected.

ALWAYS place motor in the OFF position prior to connecting the power source.

NEVER immerse the motor in liquid.

4. Noise Level

MV Motors in normal operating conditions produce a sound level equal or less than 79 dBA at a distance of three feet (~ one meter).

5. Modifications and Spare Parts

Any changes concerning the service of the motor as originally purchased, can be executed only after written approval from Finish Thompson Inc. It is recommended to use only genuine Finish Thompson Inc. spare parts and approved accessories. The use of non original spare parts or non approved accessories will void warranty and removes any responsibility on our behalf for any damage caused to people or things.

INSTALLATION

1. Unpack motor from carton. Check for shipping damage. If damage is detected, save the packaging and notify the carrier immediately.
2. Loosen the nut on the motor housing by turning it counterclockwise (as viewed from the bottom of the motor). Note that the nut remains on the motor even when loosened. See figure 1.
3. Looking into the bottom/drive-end of the motor, align the coupling half with the coupling half orientation of the pump. Aligning the coupling half with two of the slots in the motor adapter sleeve is recommended to provide a reference point. See figures 2 & 3.
4. Make sure that the rubber coupling insert (provided with the pump) is properly installed in the pump coupling half.
5. With the motor coupling half properly aligned, firmly push the motor down over the pump head until fully engaged. See figure 3.
6. The motor isn't fully coupled unless the bottom of the motor and the top of the pump are completely flush. See figure 4.

⚠ Warning: Do not position the motor handle and cord over and in front of the pump discharge.

7. Manually tighten the nut by turning it clockwise until secure. See figure 5.

Note: Do not use hand tools to tighten the nut as this may cause damage to the motor casing.



Figure 1



Figure 2



Figure 3





Figure 4



Figure 5

OPERATION

The MV Series motors incorporate an ON/OFF switch as well as a Variable Speed Control. When operating the MV Series for the first time it is recommended to turn down the speed control (Counter Clockwise) to the lowest setting. Make sure the discharge hose is properly secured. Turn on the motor with the ON/OFF switch & adjust the speed control to the desired flow rate. Both of these operations can be done with the same hand being used to support the pump utilizing the thumb. Keep in mind that flow rates will vary depending upon fluid viscosity & specific gravity. It may be necessary to operate the pump at a lower speed for high viscosity fluids. Contact factory for troubleshooting tips.

Motor Specifications			
Model	M3V	M5V	M5V-US
Part Number	106655	106658	106657
Nominal Voltage	115v	230v	230v
Input Power HP / Watts	.8 / 650	.8 / 650	.8 / 650
Hertz	50 / 60		
RPM's (Variable Speed)	3,500-10,000		
Rated Current	5.6	2.8	2.8
Enclosure	3(WP) Splash-Proof		IP24 Splash-Proof
Certificates or Approvals			
Max Viscosity cps / Density	500 / 1.8		
Duty Cycle	Continuous *		
Applicable Pump Models	PF / TB / TBP		

*Contact Factory for brush life information.

MOTOR IDENTIFICATION

(M3V Sample Label)



FINISH THOMPSON INC.

921 Greengarden Road • Erie, PA 16501-1591 U.S.A.
Ph 814-455-4478 • Fax 814-455-8518
Email fti@finishthompson.com • www.finishthompson.com

Model: M3V
Part No: 106655
Serial No.: 12345-A09

Output: 1/2 HP, 115 VAC, 50/60 Hz
5.6 amps
Enclosure: 3 (WP)

LR157411 Thermally Protected
Date of Manufacture: 3/31/2009



PARTS

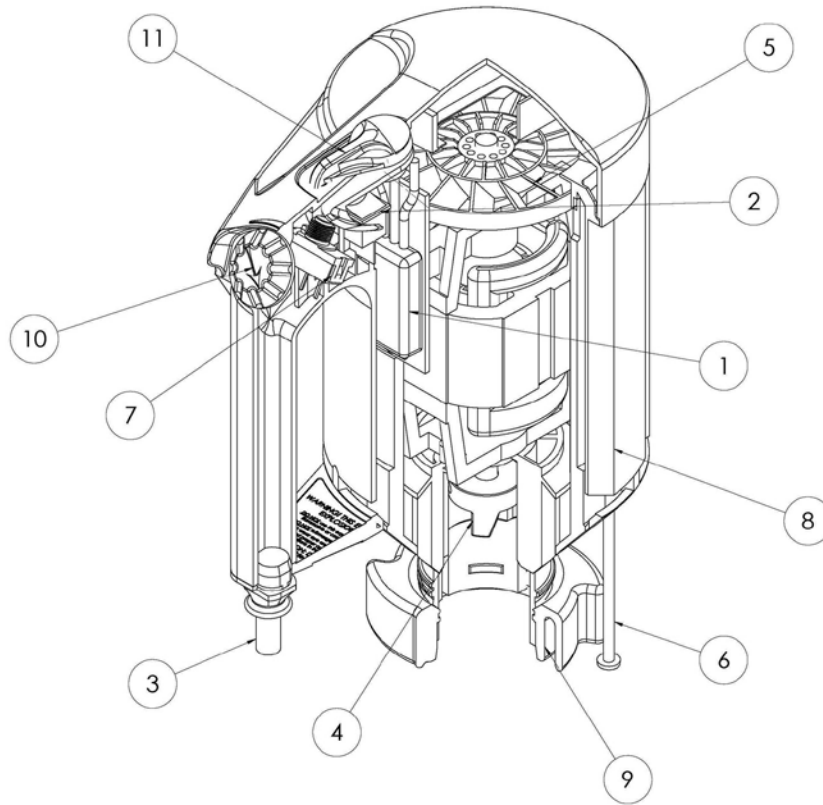

Item	Model	Quantity	Description	Part Number
1	M3V	1	Speed Control Assy	106624
1	M5V, M5V-US	1	Speed Control Assy	106624-1
2	All	1	Switch, On\Off	106029
3	M3V	1	Cord, 115 volt	106648
3A	M5V-US	1	Cord, 230 volt	106665
3B	M5V	1	Cord, 230 volt	106666
4	All	1	Motor Coupling	J100012-1
5	All		Fan Blade	106027
6	All	4	Housing Screws	106085
7	M3V	1	Circuit Breaker, 7A	107059
7	M5V, M5V-US	1	Circuit Breaker, 4A	107064
8	All	1	Housing Repair Kit	107226
9	All	1	Housing Nut	106541
10	All	1	Speed Control Knob	106538
11	All	1	On/Off Switch Knob Assembly	107225

Note: Item * is not shown in drawing.
 Housing Repair Kit includes: handle,
 cover, base, nut and labels.



FINISH THOMPSON INC.

921 Greengarden Road • Erie, PA 16501-1591 U.S.A.
 Ph 814-455-4478 • Fax 814-455-8518
 Email fti@finishthompson.com • www.finishthompson.com

Tech Service 1-800-888-3743
techservice@finishthompson.com
 Literature ID No. FT09-1080
 Part No. 106237, R5