



MSKC SERIES Multi-Stage Sealless Non-Metallic Centrifugal Pumps

Installation and Maintenance Instructions

ASSEMBLY

⚠ WARNING: Magnetic field hazard. This pump contains powerful, rare earth magnets. When the pump is disassembled (not connected to a motor) and the magnets are exposed, these magnets produce powerful magnetic fields. Individuals with cardiac pacemakers, implanted defibrillators, other electronic medical devices, metallic prosthetic heart valves, internal wound clips (from surgery), metallic prosthetic devices or sickle cell anemia must not handle or be in the proximity of the magnets contained inside the pump. Consult a health care provider for specific recommendations before working with this pump.

Unpack Pump, Drive Magnet Assembly and Hardware Package from carton and check for shipping damage.

PUMPS WITH MOTORS

Proceed to Installation Section.

PUMPS WITHOUT MOTORS

(56C frame)

1. Remove pump, drive magnet assembly and hardware package from box.

⚠ CAUTION: Keep away from metallic particles, tools and electronics.

⚠ CAUTION: Drive magnets MUST be free of metal chips.

2. Slide drive magnet assembly (item 10) onto the motor shaft until it is between 3.110" and 3.120" as measured from the motor face to the top of the drive magnet assembly. See Figure 1. Align cone point set screw (item 10B) with key slot on the motor shaft and tighten both set screws with a 5/32" Allen wrench to 140 in-lbs. (15.8 N-m).

⚠ CAUTION: Do not operate/test the motor with the drive magnet assembly exposed.

3. Carefully slide the pump assembly over the drive magnet assembly. Orient the discharge port to either the 12 or 9 o'clock position. Make sure rabbet (step) on motor is fully seated into the motor adapter (item 11). Align bolt holes in motor adapter and motor. Install (4) bolts and washers (items 14A, 14B, 14C) from hardware package.
4. Manually rotate pump assembly to ensure that the pump is not binding or rubbing on the drive magnet assembly.
5. Install the pump into the system according to installation instructions.

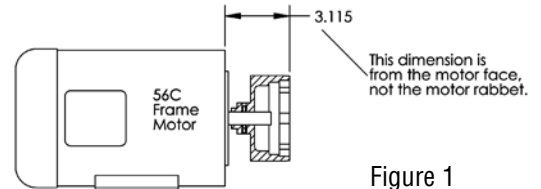

Figure 1

PUMPS WITHOUT MOTORS

(71/B14 & 80/B14 frame)

1. Remove pump, drive magnet assembly and hardware package from box.

⚠ CAUTION: Keep away from metallic particles, tools and electronics.

2. Remove screws and washers (items 12A, 12B & 12C) from impeller housing (item 1) and remove wet end assembly from motor adapter (item 11).
3. Install motor adapter onto motor (labels at top) and secure with motor bolts and washers (items 14A, 14B, 14C) from hardware package.
4. Slide the drive magnet (item 10) onto the motor shaft so that the cone point setscrew (item 10B) is aligned with the motor shaft keyway. Install the drive magnet so that it is recessed 1.016 mm (.040" +/- .005") below the surface of the motor adapter (see figure 2). Tighten both setscrews with a 5/32" Allen wrench to 15.8 N-m (140 in-lbs.).

Figure 2

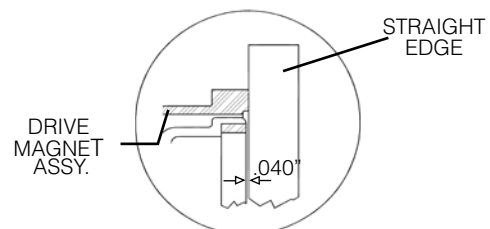

⚠ CAUTION: Do not operate/test the motor with the drive magnet assembly exposed.

⚠ CAUTION: Drive magnets MUST be free of metal chips.

Note: Prior to start-up, double check both drive magnet set screws to assure that they are firmly tightened. Failure to do so could result in internal damage. Rotate to assure clearance with the motor adapter.

⚠ WARNING: Magnets are strong. To avoid damage and pinching fingers, tightly grasp pump assembly keeping finger tips away from the area where the housing and motor adapter meet.

5. Place wet end assembly (comprised of items 1-9) into the motor adapter (item 11). Grasping the barrier at opposite bolt tabs, carefully lower the wet end assembly into the motor adapter/drive assembly. Line up the tabs of the wet end between the tabs on the motor adapter to avoid pinching fingers. Once seated, rotate the wet end until bolt holes line up.
6. Align mounting holes and install 6 mounting screws and washers (items 12A, 12B & 12C) from hardware package. Hand tighten screws using pattern shown in Figure 3.
7. Rotate motor fan to verify there is no internal binding or rubbing.
8. Install pump into the system according to installation instructions.

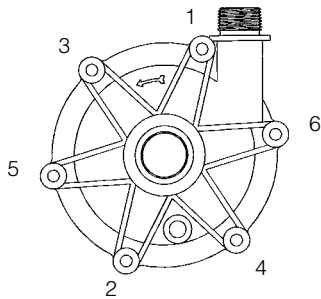

Figure 3

INSTALLATION MOUNTING

Motor should be securely fastened.

PIPING

1. Support piping near the pump to eliminate any strain on the pump casings.
2. Do not overtighten the piping on the discharge on initial installation. Damage to the discharge can occur. An o-ring can be used when there is wear and the plastic threads are loose.

Note: BSP housings are shipped with an o-ring on the discharge.

3. To minimize head loss from friction:
 - a. Increase pipe size by 1 diameter.
 - b. Use minimal number of pipe bends.
4. Keep bends and valves a minimum of 10 pipe diameters from the suction and discharge.
5. Position pump as close to the liquid source as possible.
6. Maintain a flooded suction (liquid above pump prior to being primed).
7. Ensure that the piping does not leak and suction is not prone to clogging.
8. If flexible hose is preferred, use a reinforced hose rated for the proper temperature and pressure. This helps avoid collapse or kinks.

9. Install valves on suction and discharge lines (a minimum of 10 pipe diameters from the pump).
10. For units in a suction lift system, install appropriate piping in the discharge to allow priming of the pump.

Note: This pump is not self-priming.
11. The suction valve should be completely open to avoid restricting suction flow.

⚠ CAUTION:

To stop the pump if prime is lost, use one of the following: (1) pressure switch on the discharge, (2) vacuum switch on the suction, (3) a power monitor to monitor motor power.

12. When pumping liquids that may solidify or crystallize, a flush system should be added to the piping. See Figure 4. Install water inlet and outlet valves as shown.

Note: This pump is provided with a provision for a customer installed 1/4" NPT drain in the impeller housing. See Drain Installation Section for details.

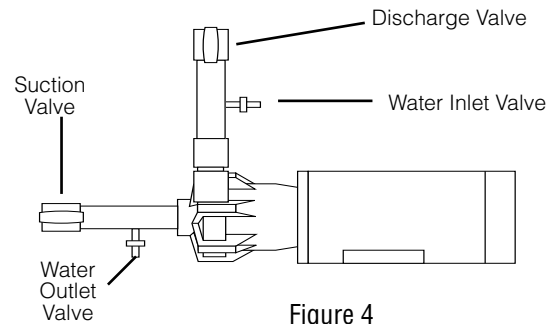

Figure 4

ELECTRICAL

Install motor according to NEC requirements and local electrical codes. Motor should have an overload protection circuit.

IMPORTANT: To verify correct motor rotation:

1. Install pump into system.
2. Fully open suction and discharge valves.
3. Allow fluid to flow into the pump. Do not allow pump to run dry (PTFE and ceramic bushings cannot be run dry without damage to pump components).
4. Jog motor (allow it to run for one or two seconds) and observe rotation of motor fan. Correct rotation is clockwise as viewed from motor fan. Refer to directional arrow on pump.

Note: A pump running backwards will pump but at a greatly reduced flow and pressure.

OPERATION

FLOODED SUCTION SYSTEM

1. Completely open suction and discharge valves
2. Start the pump and check liquid flow. If there is no flow, see the Troubleshooting section.
3. Adjust the flow rate and pressure by regulating the discharge valve. Do not attempt to adjust the flow with the suction valve.

SUCTION LIFT SYSTEM

1. Prime the system by filling the priming chamber and/or suction line with a liquid. Allow time for trapped air to work its way out.
2. If priming via filling the suction line, close the discharge valve prior to returning the suction line to the tank.

FLUSH SYSTEMS

⚠ CAUTION: Some liquids react with water.

1. Completely close suction and discharge valves.
2. Connect water supply to water inlet valve.
3. Connect drain hose to water valve.
4. Open inlet and outlet valves. Flush system until pump is clean (approximately 5 minutes).

MAINTENANCE

DISASSEMBLY

1. Disconnect power. Remove electrical wiring and motor mounting bolts.
2. Close suction and discharge valves. Disconnect piping.
3. Securely hold or clamp motor in place.
4. For 71/80 motor frame pump, skip to step 5. For 56C motor frame pumps, remove the four motor adapter bolts (item 14A) and pull the pump end away from the motor/drive magnet assembly. Set pump end on motor adapter flange with suction facing up.
5. Remove the six screws (item 12A) from the impeller housing.
6. Using a thin bladed screwdriver, gently separate the first stage housing (item 1) from the diffuser (item 5). Remove the first stage impeller housing (item 1) being careful to pull straight off so as not to damage the ceramic front spindle support. Remove the housing o-ring (item 4). Holding down on the outside of the diffuser assembly (item 5) with one hand, gently pull the first stage impeller/impeller drive shaft assembly (items 2 and 3) from the pump.
7. Remove the diffuser assembly (item 5) and the diffuser o-ring (item 6) from the top of the second stage impeller housing (item 7). Remove the second stage impeller housing, the housing o-ring, the second stage impeller assembly (items 2 & 8), and the barrier (item 9) from the motor adapter (item 11).
8. If the drive magnet assembly (item 10) or the motor needs to be replaced, do the following. On 56C frame motors, loosen the two drive magnet set screws (items 10A and 10B) with a 5/32" hex wrench, and remove the drive magnet assembly. On 71/80 frame motors, insert a 5/32" hex wrench into the access hole on the top of the motor adapter (item 11) and loosen the two set screws. Remove the drive magnet assembly from the motor shaft. Remove the motor adapter if the motor is being replaced.

⚠ CAUTION:

Keep the drive magnet and impeller assemblies away from metal chips or particles.

EXAMINATION

1. Check impeller bushings (item 8A) in both the impeller assembly (item 8) and the impeller drive shaft (item 3), check both thrust rings (item 2A), both ceramic housing rings, and both the barrier ceramic post and the first stage impeller housing ceramic post for cracks, chips, scoring or excess wear. See figure 5. Replace as required.
2. Check for loose magnets on drive magnet assembly or rubbed areas on the impeller or barrier assemblies. Contact your distributor or FTI Technical Service if a problem is found.
3. If you do not remove the drive magnet assembly, check the set screws for tightness before reassembly.

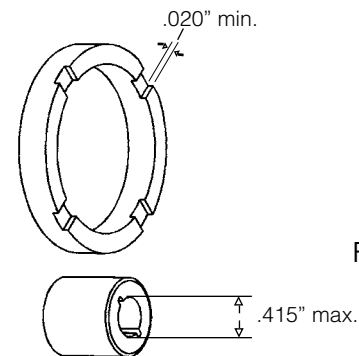

Figure 5

BUSHING REPLACEMENT

1. To remove the bushing in the second stage, insert 1/16" pin punch into balance hole (inner circle of 4 holes) of impeller drive. Gently tap the bushing out of the back of the impeller drive. The punch may need to be moved to a different hole if the bushing is difficult to remove.
2. To replace the bushing, clean the impeller bore. Insert the new bushing into the back of the impeller drive by aligning the bushing with the impeller bore. Press gently until the bushing bottoms out (use a block of wood and mallet if necessary).
3. If the bushing in the impeller drive shaft is worn and needs to be replaced, the complete impeller drive shaft with bushing (item 3) will need to be purchased. Grasp the impeller assembly in one hand and pull the impeller drive shaft from it.

REASSEMBLY

If the drive magnet assembly (item 10) is to be replaced, install as follows. On a 56C motor frame, slide the drive magnet assembly (item 10) onto the motor shaft until it is between 3.110" and 3.120" as measured from the motor face to the top of the magnet assembly. See figure 1. Align cone point set screw (item 10B) with key slot on the motor shaft and tighten both set screws with a 5/32" Allen wrench to 140 in-lbs. (15.8 N-m).

For 71/B14 frame motors - Install the motor adapter (item 11) onto the motor face. Slide the drive magnet (item 10) onto the motor shaft so that the cone point setscrew (item 10B) is aligned with the motor shaft keyway. Install the drive magnet so that it is recessed 1.016 mm (.040" +/- .005") below the surface of the motor adapter (see figure 2). Tighten both set-screws with a 5/32" Allen wrench to 15.8 N-m (140 in-lbs.).

For 56C motor frame pumps:

Place the barrier (item 9) onto the motor adapter (item 11). Align the bolt hole tabs and press the barrier into the motor adapter until it snaps in place. Place the second stage impeller assembly (items 2 & 8) into the barrier (note orientation of the recessed square in top of impeller assembly). Proceed to step 2.

For 71 and 80 motor frame pumps:

1. If possible, set motor on fan cover with drive magnet assembly facing up. Place the second stage impeller assembly (comprised of items 2 and 8) into the barrier (item 9). Grasping the barrier at opposite bolt tabs, carefully lower the barrier assembly into the motor adapter (item 11). Line up the tabs of the barrier between the tabs on the motor adapter to avoid pinching fingers. Once seated, rotate the barrier until the bolt holes line up.
2. Install the housing o-ring (item 4) on the barrier. Lubricate the o-ring with a compatible lubricant to facilitate o-ring installation.
3. Install the second stage impeller housing (item 7) onto the barrier being careful not to dislodge the o-ring. Align the bolt hole tabs and gently press together (bolt clearance alignment is critical).
4. Install and lubricate the diffuser o-ring (item 6). Install the diffuser assembly (item 5) making sure to keep bolt clearance alignment straight and making sure not to dislodge the o-ring.
5. If the first stage impeller drive shaft (item 3) was replaced, reassemble it to the impeller assembly by matching the three tabs on the end of the drive shaft with the three recessed slots in the impeller assembly (item 2) and press together.
6. Looking through the hole in the center of the diffuser assembly, note the orientation of the square recess in the top of the impeller. Insert the square end of the drive shaft through the hole and into the square recessed hole in the top of the impeller. Press gently but firmly to seat the drive shaft.
7. Install and lubricate the housing o-ring. Coming straight down, gently place the impeller housing (item 1) onto the pump with the ceramic front spindle support sliding into the bushing on top of the first stage impeller assembly (items 2 and 3). Orient the housing with the directional arrow on top, the drain boss location on the bottom and with the mounting holes aligned. Install the six mounting bolts, washers, and lock washers (items 12A, 12B, and 12C). Make sure the housing o-ring is not dislodged or pinched. Hand tighten the mounting bolts to pull the pump together using the pattern shown in figure 3.

8. After the housing is tightened down, insert a screwdriver into the suction and push down on the front of the first stage impeller assembly (Note: Do not press on gray thrust ring) to completely set the impeller drive shaft (item 3) into the second stage impeller (item 8). Push firmly on the three areas separated by the spindle support arms in the suction. Rotate the motor fan to verify nothing is rubbing.
9. **56C frame pumps.** Carefully slide the pump assembly over the drive magnet assembly. Orient the discharge port to either the 12 or 9 o'clock position. Make sure the rabbet on the motor is fully seated into the motor adapter (item 11). Align the bolt holes in the motor adapter and the motor. Install 4 bolts and washers (items 14A,14B,14C) and tighten securely.

OPTIONAL DRAIN INSTALLATION SECTION

1. Remove the impeller housing from the pump assembly.
 2. Clamp the impeller housing to a drill press table.
 3. Using a 7/16" drill and the molded boss as a guide, drill completely through the molded boss into the interior of the impeller housing. De-burr the hole on the inside of the impeller housing. See Figure 6.
- ! CAUTION:** Do not tap too deep or the impeller housing may be damaged.
4. Using a 1/4" NPT tap, tap the hole in the molded boss to the appropriate depth.
 5. Install drain plug or valve, being careful not to overtighten.

Figure 6

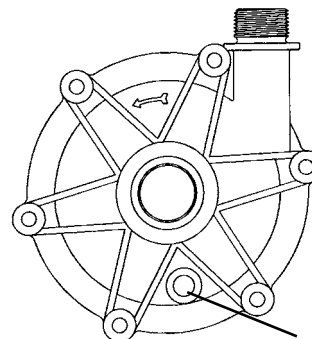

Drain fitting molded boss. Use as a guide for drilling and tapping 1/4" NPT.

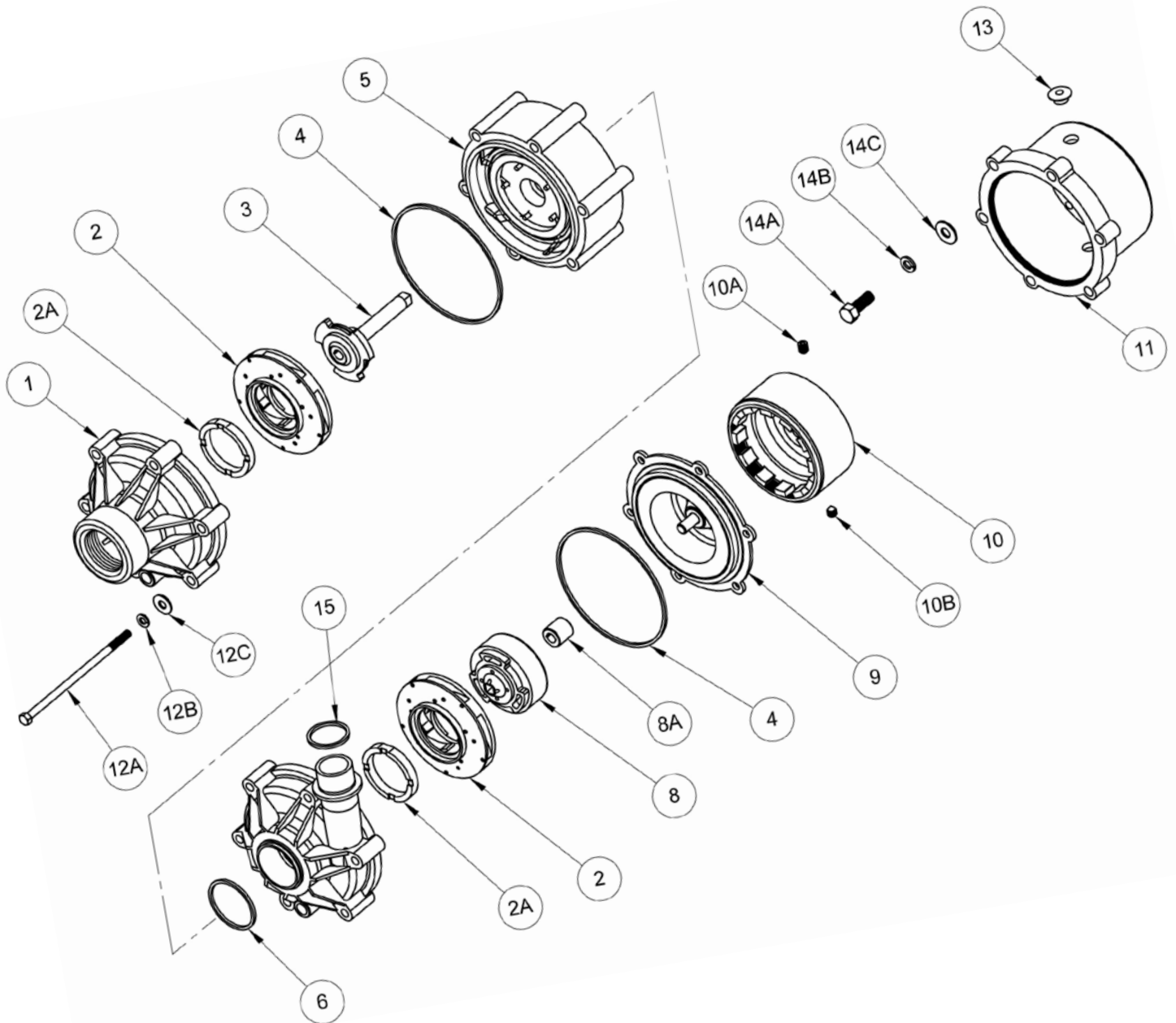

Note: O-ring (item 15) is used only with BSP threads.

MSKC MULTI-STAGE SPARE PARTS					
Item	Description	Frame Size	Part Number		Qty.
			Polypropylene	PVDF	
1	Impeller Housing – first stage	NPT	A103195-1	A103195-2	1
		BSP	A103195-3	A103195-4	
2	Impeller with thrust ring				2*
	3.00"		A101983-17	A101983-18	
	3.19"		A101983-15	A101983-16	
	3.50"		A101983-2	A101983-5	
	3.88"	A101983-3	A101983-6		
2A	Thrust ring – PTFE				1
	3.00"/3.19"		J103893		
	3.50"/3.88"		J101606		
3	Impeller drive shaft with carbon bushing	All	A103270-1	A103270-4	1
	Impeller drive shaft with PTFE bushing		A103270-2	A103270-5	
	Impeller drive shaft with ceramic bushing		A103270-3	A103270-6	
4	Housing o-ring – FKM	All	J102389		2
	Housing o-ring – EPDM		J102585		
5	Diffuser Assembly	All	A103242-1	A103242-4	1
6	Diffuser o-ring – FKM	All	J102447		1
	Diffuser o-ring - EPDM		J102446		
7	Impeller Housing – second stage	NPT/ BSP	107787-1	107787-2	1
8	Impeller Drive with carbon bushing	All	A103269-1	A103269-4	1
	Impeller Drive with PTFE bushing		A103269-2	A103269-5	
	Impeller Drive with ceramic bushing		A103269-3	A103269-6	
8A	Impeller bushing – carbon	All	J102387		1
	Impeller bushing – PTFE		J102790		
	Impeller bushing – ceramic		J103617		
9	Barrier	All	107788-1	107788-2	1
10	Drive Magnet Assembly	56C	A101990-15		1
		71/B14	A101990-13		
		80/B14	A101990-14		
10A	Set Screw – knurled point	All	J104219		1
10B	Set Screw – cone point	All	J104220		1
11	Motor Adapter	56C	A101991-3		1
		71/B14	A101991-1		
		80/B14	A101991-2		
12A	C/S hex hd. ¼-20 x 5-1/2" LG. SS	All	J103873		6
12B	¼" lock washer	All	J100672		6
12C	¼" flat washer	All	J100113		6
13	Plug for motor adapter	All	J102878		2
14A	Motor Adapter Bolts				4
	3/8-16 x 1" SS hex hd. cap screw	56C	J100114		
	M6 x 16mm SS hex hd. cap screw	71 & 80	J102884		
14B	Motor Adapter Lock Washer				4
	3/8" SS lock washer	56C	J100115		
	¼" SS lock washer	71 & 80	J100672		
14C	Motor Adapter Flat Washers				4
	3/8" SS flat washer	56C	J100128		
	¼" SS flat washer	71 & 80	J100113		
15	Discharge o-ring - FKM	BSP	J102391		1
	Discharge o-ring - EPDM		J102713		

*May be two different size impellers. See below. Check model number of serial number of label to determine impeller combinations. Example: MSKCPCVN15C. The underline position indicates impeller combination.

$1 = 3.88 + 3.88$

$2 = 3.5 + 3.88$

$3 = 3.5 + 3.5$

$4 = 3.19 + 3.5$

$5 = 3.0 + 3.5$

TROUBLESHOOTING

GENERAL NOTES:

1. Do not pump liquids containing metal fines.
2. Orient the discharge port to either 12 or 9 o'clock position.
3. If magnets decouple, stop the pump immediately. The rare earth magnets used in this pump are more resistant to demagnetization than ceramic magnets, but operating the pump with the magnets decoupled will eventually weaken the magnets.
4. Plastic pumps will expand and contract with temperature so periodically check and hand-tighten screws. This pump is designed to accept an o-ring on the discharge flange and inlet chamfer as a backup to the NPT or BSP threads to ensure leak-free operation after temperature cycling.
5. Fitting o-rings on discharge flange and inlet chamfer is possible.

NO DISCHARGE

1. Air leaks in suction piping.
2. Pump not primed.
3. Discharge head too high.
4. Suction lift too high or insufficient NPSHA. Suction lift should be 2 feet above NPSHR.
5. Closed valve.
6. Viscosity or specific gravity too high (magnets uncoupled).

INSUFFICIENT DISCHARGE

1. Air leaks in suction piping.
2. Discharge head higher than anticipated.
3. Suction lift too high or insufficient NPSHA. Suction lift should be 2 feet above NPSHR.
4. Clogged suction line, foot valve or crimp in hose.
5. Foot valve too small.
6. Foot valve or suction opening not submerged enough.
7. Incorrect pump rotation.

INSUFFICIENT PRESSURE

1. Air or gasses in liquid.
2. Impeller diameter too small.
3. Discharge head higher than anticipated.
4. Incorrect pump rotation.

LOSS OF PRIME

1. Leaking suction or discharge line.
2. Suction lift too high or insufficient NPSHA. Should be 2 feet above NPSHR.
3. Air or gasses in liquid.
4. Foreign matter in impeller.
5. Leaking valve.

EXCESSIVE POWER CONSUMPTION

1. System head lower than rating. Pumps too much liquid.
2. Specific gravity or viscosity of liquid pumped is too high or higher than that defined in application.
3. Binding pump parts.

VIBRATION/NOISE

1. Excess bearing wear.
2. Drive magnet uncoupled.
3. Loose magnet.
4. Pump cavitating.
5. Motor or piping not properly secured.
6. Foreign object in impeller.

WARRANTY

Finish Thompson, Inc (manufacturer) warrants this pump product to be free of defects in materials and workmanship for a period of one year from date of purchase by original purchaser. If a warranted defect, which is determined by manufacturer's inspection, occurs within this period, it will be repaired or replaced at the manufacturer's option, provided (1) the product is submitted with proof of purchase date and (2) transportation charges are prepaid to the manufacturer. Liability under this warranty is expressly limited to repairing or replacing the product or parts thereof and is in lieu of any other warranties, either expressed or implied. This warranty does apply only to normal wear of the product or components. This warranty does not apply to products or parts broken due to, in whole or in part, accident, overload, abuse, chemical attack, tampering, or alteration. The warranty does not apply to any other equipment used or purchased in combination with this product. The manufacturer accepts no responsibility for product damage or personal injuries sustained when the product is modified in any way. If this warranty does not apply, the purchaser shall bear all cost for labor, material and transportation.

Manufacturer shall not be liable for incidental or consequential damages including, but not limited to, process down time, transportation costs, costs associated with replacement or substitution products, labor costs, product installation or removal costs, or loss of profit. In any and all events, manufacturer's liability shall not exceed the purchase price of the product and/or accessories.

ORDERING SPARE PARTS

Spare parts can be ordered from your local distributor. Always refer to the pump model number to avoid error.

OTHER FINISH THOMPSON PRODUCTS

Drum Transfer Pumps are available in sanitary construction, stainless steel, polypropylene and CPVC. Flows to 40 gpm, discharge head to 80 feet and viscosities to 15,000 cP are available.

Portable Mixers for turbine mixing and blending handle up to 1,000 cP with gentle, non-vortexing circulation. Available in 316 stainless steel construction.

Centrifugal Pumps in polypropylene, PVDF, and stainless steel offer a wide variety of sealing materials. Flows to 250 gpm, discharge head to 130 feet, and temperature to 220°F (104°C) are available.

For more information, contact Finish Thompson Inc. or call our Technical Service Hot Line, 1-800-888-3743, if you have any questions regarding product operation or repair.



FINISH THOMPSON INC.

921 Greengarden Road • Erie, PA 16501-1591 U.S.A.
Ph 814-455-4478 • Fax 814-455-8518
Email fti@finishthompson.com • www.finishthompson.com

Service 800-888-3743
P/N J104018, Rev. 11, 2/11/11



FT01-843K