



KC 5.5, 6, 6H, 7, 8, & 10 SERIES Non-Metallic Centrifugal Pumps Installation and Maintenance Instructions

ASSEMBLY

Unpack the pump, drive magnet assembly and hardware package from carton and check for shipping damage.

⚠ WARNING: Magnetic field hazard. This pump contains powerful rare earth magnets. When the pump is disassembled (not connected to a motor) and the magnets are exposed, these magnets produce powerful magnetic fields. Individuals with cardiac pacemakers, implanted defibrillators, other electronic medical devices or sickle cell anemia must not handle or be in the proximity of the magnets contained inside the pump. Consult a health care provider for specific recommendations before working with this pump.

ATEX COMPLIANT PUMPS

All assembly, installation, and maintenance instructions are the same as standard pumps with the exceptions noted on page 4 under "Safety Precautions for ATEX pumps."

PUMPS WITH MOTORS

Proceed to Installation Section.

PUMPS WITHOUT MOTORS

56C frame

1. Remove the pump, drive magnet assembly and hardware package from box.

⚠ CAUTION: Keep away from metallic particles, tools and electronics. Drive magnets **MUST** be free of metal chips.

2. Slide drive magnet assembly (item 6) onto the motor shaft until it is between 3.110" and 3.120" as measured from the motor face to the top of the drive magnet assembly. See Figure 1. Align set screw (item 6B) with flat or key slot on the motor shaft and tighten both set screws with a 5/32" Allen wrench to 70 in.-lbs. (7.9 N-m).

⚠ CAUTION: Do not operate/test the motor with the drive magnet assembly exposed.

⚠ WARNING: Magnets are strong. To avoid damage and pinching fingers, tightly grasp pump assembly keeping finger tips away from the area where the motor adapter and motor meet.

3. Carefully slide the pump assembly over the drive magnet assembly. Orient the discharge port to either the 12 or 9 o'clock position. Make sure rabbet (step) on motor is fully seated into the motor adapter (item 5). Align bolt holes in motor adapter and motor. Install (4) bolts and washers (items 10A, 10B, & 10C) from hardware package.

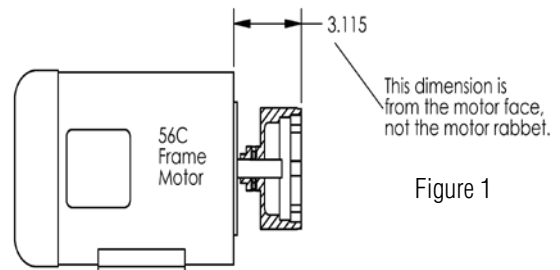

Figure 1

4. Manually rotate pump assembly to ensure that the pump is not binding or rubbing on the drive magnet assembly.
5. Install the pump into the system according to installation instructions.

PUMPS WITHOUT MOTORS

63/B14, 71/B14 & 80/B14

1. Remove pump, drive magnet assembly and hardware package from box.

⚠ CAUTION: Keep away from metallic particles, tools and electronics.

2. Remove screws and washers (items 9A, 9B & 9C) from impeller housing (item 1) and remove pump assembly from motor adapter (item 5).
3. For 63 frame pumps - Adjust the single setscrew located in the middle of the supplied shaft adapter so that it protrudes slightly into the inside bore. Align that protruding setscrew with the keyway or flat on the motor shaft and slide on the shaft adapter until it bottoms out. Tighten the single setscrew into the keyway, and then tighten the two setscrews on the end of the adapter onto the motor shaft.
4. Install the motor adapter (item 5) onto the motor with the access holes top and bottom. Secure with supplied hardware (items 10A, 10B, and 10C). On 63 frame pumps, from the motor side, insert the supplied gray spacer into the base of the motor adapter and secure both to the motor.

- For 63 frame pumps - Screw the cone point drive magnet assembly setscrew (item 6B) in so that it protrudes slightly into the drive bore. Align the protruding setscrew point with the key slot on the shaft adapter and slide the drive magnet assembly (item 6) on. Adjust the drive magnet assembly (item 6) so that it is 1.016 mm (.040 +/- .005) below the face of the motor adapter (see figure 2) and tighten both setscrews with a 5/32" Allen wrench to 7.9 N.m (70 in. lbs.).

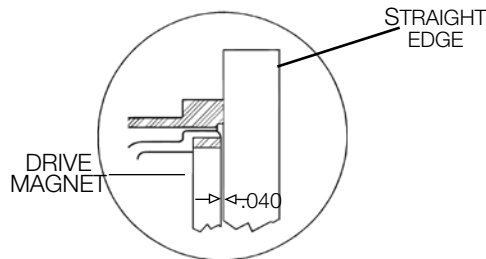

Figure 2

For 71 and 80 frame - Align the cone point set screw (item 6B) on the motor shaft and slide the drive magnet assembly (item 6) onto the motor shaft. Adjust the drive so that it is 1.016 mm (.040 + or -.005) below the face of the motor adapter (see figure 2). Tighten both setscrews with a 5/32" Allen wrench to 7.9 N-m (70 in-lbs.).

- Place the impeller assembly (comprised of items 2 and 3) in barrier (item 4). Grasping the barrier at opposite bolt tabs, carefully lower the barrier assembly into the motor adapter/drive assembly. Line up the tabs of the barrier between the tabs on the motor adapter to avoid pinching fingers. Once seated, rotate the barrier until bolt holes line up.
- Install the o-ring (item 7) on the barrier. Lubricate the o-ring with a compatible lubricant to facilitate installation.
- Place the impeller housing (item 1) on the barrier being careful not to dislodge the o-ring.
- Align mounting holes and install 6 mounting screws and washers (items 9A, 9B & 9C) from hardware package. Hand tighten screws using pattern shown in Figure 3.

Manually rotate the pump assembly to ensure that the pump is not binding or rubbing on the drive magnet assembly.

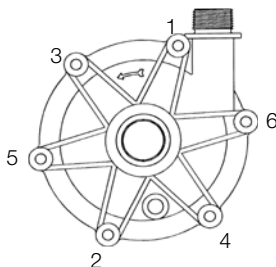

Figure 3

- Install pump into the system according to installation instructions.

⚠ CAUTION: Do not operate/test the motor with the drive magnet assembly exposed.

⚠ CAUTION: Drive magnets MUST be free of metal chips.

Note: Prior to start-up, double check the two set screws to assure that they are firmly tightened. Failure to do so could result in internal damage. Rotate to assure clearance with the motor adapter.

⚠ WARNING: Magnets are strong. To avoid damage and pinching fingers, tightly grasp pump assembly keeping finger tips away from the area where the housing and motor adapter meet.

INSTALLATION MOUNTING

Motor should be securely fastened.

PIPING

- Support piping near the pump to eliminate any strain on the pump casings.
- Do not overtighten the piping on the discharge on initial installation (i.e., down to the o-ring). Damage to the discharge can occur. The o-ring is used only when there is wear and the plastic threads are loose.
- To minimize head loss from friction:
 - Increase pipe size by 1 diameter.
 - Use minimal number of pipe bends.
- Keep bends and valves a minimum of 10 pipe diameters from the suction and discharge.
- Position pump as close to the liquid source as possible.
- Maintain a flooded suction (liquid above pump prior to being primed).
- Ensure that the piping does not leak and suction is not prone to clogging.
- If flexible hose is preferred, use a reinforced hose rated for the proper temperature and pressure. This helps avoid collapse or kinks.
- Install valves on suction and discharge lines (a minimum of 10 pipe diameters from the pump).
- For units in a suction lift system, install appropriate piping in the discharge to allow priming of the pump.
- The suction valve should be completely open to avoid restricting suction flow.

- ⚠ CAUTION:** To stop the pump if prime is lost, use one of the following: (1) pressure switch on the discharge, (2) vacuum switch on the suction, (3) a motor minder to monitor motor current.

- When pumping liquids that may solidify or crystallize, a flush system should be added to the piping. See Figure 4. Install water inlet and outlet valves as shown.

Note: This pump is provided with a provision for a customer installed 1/4" NPT drain in the impeller housing. See Drain Installation Section for details.

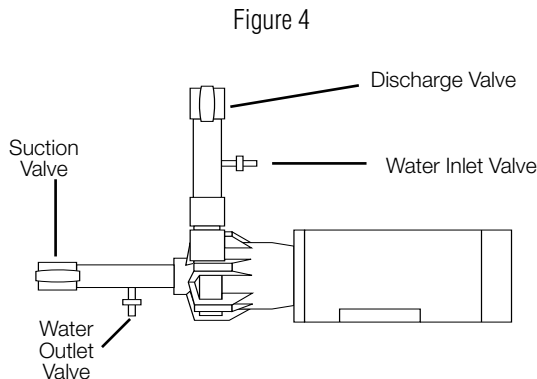

ELECTRICAL

- Install the motor according to NEC requirements and local electrical codes. The motor should have an overload protection circuit.
- Wire the motor for clockwise rotation when facing the fan end of the motor.
- To verify correct rotation of the motor:
 - Install the pump into the system.
 - Fully open the suction and discharge valves
 - Allow fluid to flow into the pump. Do not allow the pump to run dry (PTFE and ceramic bushings can't be run dry without damage to pump components).
 - Jog the motor (allow it to run for only one to two seconds) and observe the rotation of the motor fan. Refer to the directional arrow on the pump if needed.

Note: A pump running backward will pump but at a greatly reduced flow and pressure.

OPERATION

FLOODED SUCTION SYSTEM

- Completely open suction and discharge valves
- Start the pump and check liquid flow. If there is no flow, see the Troubleshooting section.
- Adjust the flow rate and pressure by regulating the discharge valve. Do not attempt to adjust the flow with the suction valve.

SUCTION LIFT SYSTEM

- Prime the system by filling the priming chamber and/or suction line with a liquid. Allow time for trapped air to work its way out.
- If priming via filling the suction line, close the discharge valve prior to returning the suction line to the tank.

FLUSH SYSTEMS

- ⚠ CAUTION:** Some liquids react with water.

- Completely close suction and discharge valves.
- Connect water supply to water inlet valve.
- Connect drain hose to water valve.
- Open inlet and outlet valves. Flush system until pump is clean (approximately 5 minutes).

MAINTENANCE

DISASSEMBLY

- Disconnect power. Remove electrical wiring and motor mounting bolts.
- Close suction and discharge valves. Disconnect piping.
- Securely hold or clamp the motor in place.
- For metric pumps, skip to step 5. For 56C frame pumps, remove the four motor adapter bolts (items 10A, 10B, & 10C) and pull the pump end straight off of the motor face. Place the pump end on the table with the adapter flange on the table and the suction pointing straight up.
- Remove the six housing bolts (item 9A, 9B, & 9C) from the pump.
- Using a thin bladed screwdriver, gently separate the impeller housing (item 1) from the barrier (item 4). Remove the housing o-ring (item 7). Gently separate the barrier from the motor adapter (item 5). On metric pumps, carefully separate and rotate the barrier tabs so that they are located in between the motor adapter bolt holes. Gripping the tabs, pull the barrier and impeller assembly from the pump. Remove the impeller assembly (items 2 and 3) from the barrier.
- Remove the drive magnet assembly (item 6) using a 5/32" hex wrench on the two set screws. Metric pumps have access holes in the motor adapter to loosen set screws.

- ⚠ CAUTION:** Keep the drive magnet and impeller assemblies away from metal chips or particles.

EXAMINATION:

- Check impeller drive bushing (item 3A), thrust ring, ceramic thrust ring and shaft for cracks, chips, scoring or excess wear. See Figure 5. Replace as required.

2. Check for loose magnets on drive assembly or rubbed areas on impeller or barrier assemblies. Contact your distributor or FTI Technical Service if a problem is found.
3. If you did not remove the drive magnet assembly, check the set screws for tightness before reassembly.

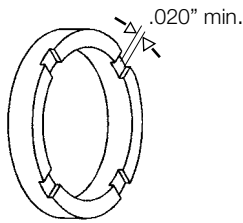
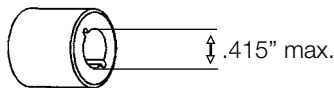

Figure 5



BUSHING REPLACEMENT

1. To remove the bushing, insert a 1/16" pin punch into balance hole (inner circle of 4 holes) of impeller assembly (items 2 & 3). Gently tap the bushing out of the back of the impeller assembly. The punch may need to be moved to a different hole if the bushing is difficult to remove.
2. To replace the bushing, clean the impeller bore. Insert the new bushing into the back of the impeller assembly by aligning the bushing with the impeller bore. Press gently until the bushing bottoms out (use a block of wood and mallet if necessary).

REASSEMBLY

1. 56C pumps - Insert the barrier (item 4) into the motor adapter (item 5). Align the barrier tabs with the motor adapter bolt holes and press/pop into place. Install the impeller assembly (items 2 and 3) into the barrier. Lubricate the housing o-ring (item 7) with a chemically compatible lubricant and install. Carefully place the impeller housing (item 1) onto the barrier, lining up the discharge with a set screw access hole (top) in the motor adapter. Be careful not to dislodge the o-ring. Install the six bolts and washers (items 9A, 9B, and 9C) and hand tighten the screws following the pattern shown in figure 3.

After verifying the setting and setscrews tension on the drive magnet assembly, grip the pump end by the discharge and the opposing front edge of the motor adapter and install the pump end on to the motor. Secure to the motor with correct hardware (items 10A, 10B, and 10C).

⚠ CAUTION: Do not allow fingers between the motor face and the motor adapter.

2. For metric pumps - Follow assembly instructions for metric pumps on page 1, steps 3 through 10.

Note: Plastic pumps will expand and contract with temperature, so periodically check and hand tighten screws. This pump is designed to accept an o-ring on the discharge flange and inlet chamfer as a backup to the NPT or BSP threads to ensure leak-free operation after temperature cycling.

OPTIONAL DRAIN INSTALLATION SECTION

1. Remove the impeller housing from the pump assembly.
 2. Clamp the impeller housing to a drill press table.
 3. Using a 7/16" drill and the molded boss as a guide, drill completely through the molded boss into the interior of the impeller housing. De-burr the hole on the inside of the impeller housing. See Figure 6.
- ⚠ CAUTION:** Do not tap too deep or the impeller housing may be damaged.
4. Using a 1/4" NPT tap, tap the hole in the molded boss to the appropriate depth.
 5. Install drain plug or valve, being careful not to overtighten.

Figure 6

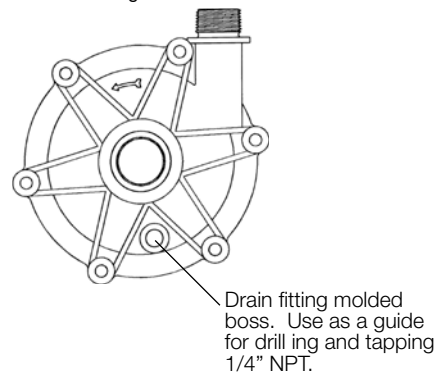

SAFETY PRECAUTIONS FOR ATEX PUMPS

⚠ CAUTION: Proper o-ring material must be chosen for the fluid being pumped. Improper material selection could lead to swelling and be a possible source of leaks. This is the responsibility of the end user.

⚠ WARNING: The pump must be checked for leaks on a regular basis. If leaks are noticed, the pump must be repaired or replaced immediately.

⚠ WARNING: The pump must be cleaned on a regular basis to avoid dust buildup greater than 5 mm.

⚠ WARNING: ATEX pumps must use a power monitor, flow switch, pressure switch or similar device to help protect against dry running, closed discharge valve and decoupling. Any of these conditions could lead to a rise in surface temperature of the pump.

TEMPERATURE CLASSIFICATION

The surface temperatures of the KC ATEX Series pumps depend upon the temperature of the fluid that is being pumped. The following chart lists different fluid temperatures and the corresponding pump surface temperatures:

Fluid Temperature	Maximum Surface Temperature	Temperature Class	Maximum Allowable Surface Temperature
80°F (27°C)	122°F (50°C)	T6	85°C
185°F (85°C)	192°F (89°C)	T4	135°C
220°F (104°C)	248°F (120°C)	T3	200°C

KC5.5, 6, 6H, 7, 8, 10 EXPLODED VIEW

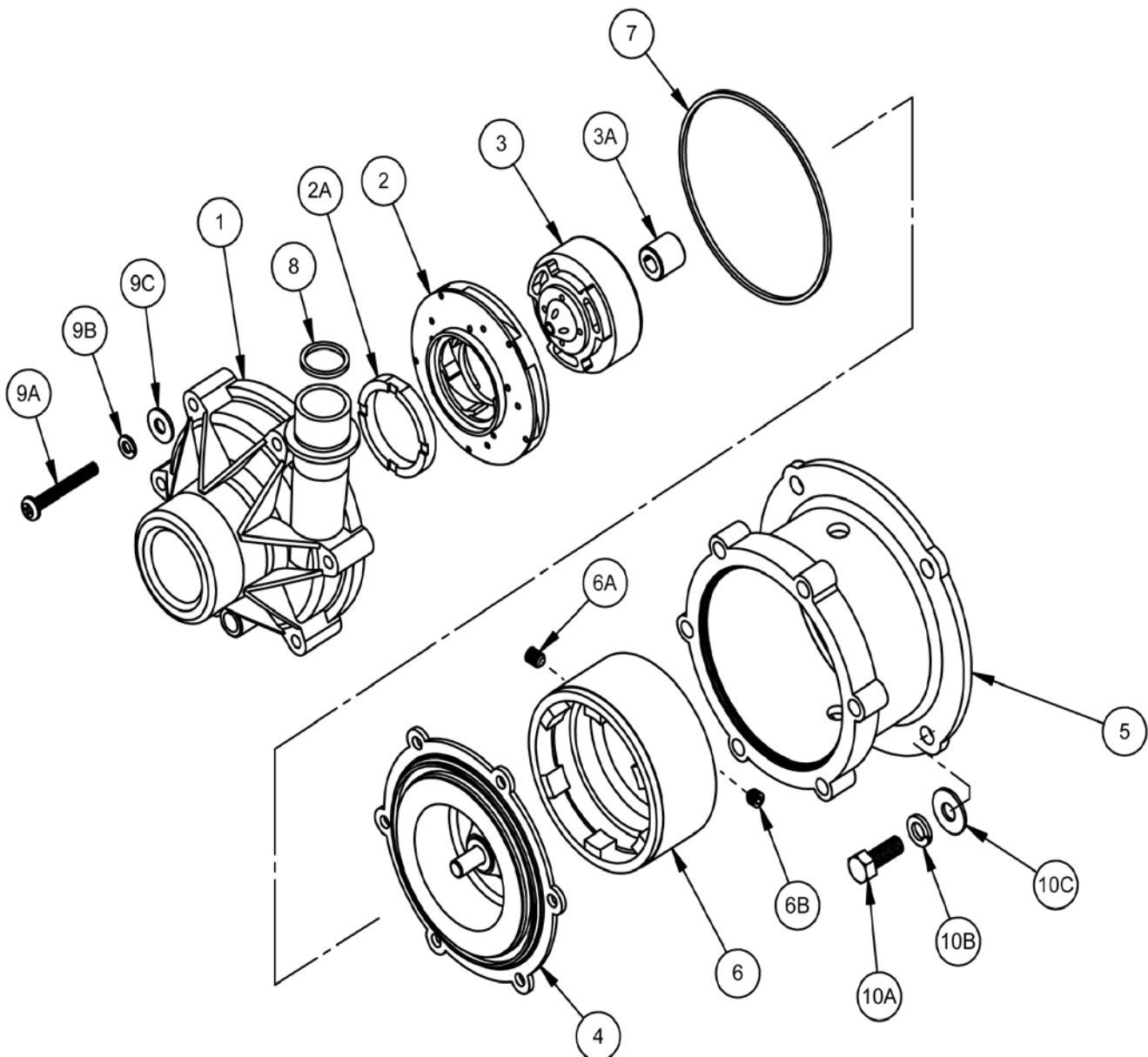

KC5.5, 6, 6H, 7, 8, 10 PARTS LIST

Item	Qty.	Description	Pump	Thread	Polypropylene Part Number	PVDF & ATEX Part Number
1	1	Impeller housing with thrust ring	KC5.5,6, 6H	NPT	A101981-1	A101981-3
			KC7,8, 10		A101981-7	A101981-9
1	1	Impeller housing with thrust ring & EPDM O-ring	KC5.5,6, 6H	BSP	A101982-7	A101982-8
			KC7,8,10	BSP	A101982-15	A101982-16
1	1	Impeller housing with thrust ring & Viton O-ring	KC5.5,6,6H	BSP	A101982-3	A101982-4
			KC7,8,10	BSP	A101982-11	A101982-12
2	1	Impeller head with thrust ring	KC5.5 (3.0")	N/A	A101983-10	A101983-11
			KC6 (3.19")	N/A	A101983-1	A101983-4
			KC6H (3.88")	N/A	A101983-13	A101983-14
			KC7 (3.0")	N/A	A101983-17	A101983-18
			KC7 (3.19")	N/A	A101983-15	A101983-16
			KC8 (3.50")	N/A	A101983-2	A101983-5
2A	1	PTFE thrust ring	KC5.5,6	N/A	J102388	J102388
			KC6H	N/A	J104045	J104045
			KC7	N/A	J103893	J103893
			KC8, 10	N/A	J101606	J101606

Choosing the correct magnet coupling:

KC5.5,6 & 7 - 6-pole magnet is standard, but can be upgraded to 8, 10 or 12 pole.

KC6H & 8 - 8-pole magnet is standard, but can be upgraded to 10 or 12 pole.

KC10 - 10-pole magnet is standard, but can be upgraded to 12.

NOTE: Pole refers to the number of magnets used in the magnet coupling. Poles must match or pump will decouple. If uncertain of the number of poles you have, contact FTI at 1-800-888-3743. Have your serial number or part number available.

3	1	Impeller hub w/carbon bushing	6-pole	N/A	A102746-1	A102746-2
			8-pole	N/A	A102746-4	A102746-15
			10-pole	N/A	A102746-7	A102746-8
			12-pole	N/A	A102746-16	A102746-18
3	1	Impeller hub w/PTFE bushing	6-pole	N/A	A102746-10	A102746-13
			8-pole	N/A	A102746-11	A102746-14
			10-pole	N/A	A102746-12	A102746-15
			12-pole	N/A	A102746-17	A102746-19
3	1	Impeller hub w/ceramic bushing	6-pole	N/A	A102746-20	A102746-21
			8-pole	N/A	A102746-22	A102746-23
			10-pole	N/A	A102746-24	A102746-25
			12-pole	N/A	A102746-26	A102746-27
3A	1	Impeller bushing, carbon	All	N/A	J102387	J102387
		Impeller bushing, PTFE	All	N/A	J102790	J102790
		Impeller bushing, ceramic	All	N/A	J103617	J103617
4	1	Barrier w/shaft	All	N/A	A101703-1	A101703-2
5	1	Motor adapter				
		56C	All	N/A	A101991-3	A101991-3
		63 frame	All	N/A	A101991-8	A101991-8
		63 frame ATEX version	All	N/A	N/A	A101991-11
		71/B14 frame	All	N/A	A101991-1	A101991-1
		71/B14 frame ATEX version	All	N/A	N/A	A101991-10
		80/B14 frame	All	N/A	A101991-2	A101991-2
		80/B14 frame ATEX version	All	N/A	N/A	A101991-9

Choosing the correct magnet coupling:

KC5.5,6 & 7 - 6-pole magnet is standard, but can be upgraded to 8, 10 or 12 pole.

KC6H & 8 - 8-pole magnet is standard, but can be upgraded to 10 or 12 pole.

KC10 - 10-pole magnet is standard, but can be upgraded to 12.

NOTE: Pole refers to the number of magnets used in the magnet coupling. Poles must match or pump will decouple. If uncertain of the number of poles you have, contact FTI at 1-800-888-3743. Have your serial number or part number available.

Item	Qty.	Description	Pump	Thread	Polypropylene Part Number	PVDF & ATEX Part Number
6	1	Drive magnet assembly w/set screw				
		56C (56C ATEX not available)	6-pole	N/A	A101990-3	A101990-3
		63 Frame	6-pole	N/A	A101990-11	A101990-11
		71/B14 Frame	6-pole	N/A	A101990-1	A101990-1
		80/B14 Frame	6-pole	N/A	A101990-2	A101990-2
6	1	Drive magnet assembly w/set screw				
		56C (56C ATEX not available)	8-pole	N/A	A101990-6	A101990-6
		63 Frame	8-pole	N/A	A101990-12	A101990-12
		71/B14 Frame	8-pole	N/A	A101990-4	A101990-4
		80/B14 Frame	8-pole	N/A	A101990-5	A101990-5
6	1	Drive magnet assembly w/set screw				
		56C (56C ATEX not available)	10-pole	N/A	A101990-7	A101990-7
		63 Frame	10-pole	N/A	A101990-19	A101990-19
		71/B14 Frame	10-pole	N/A	A101990-8	A101990-8
		80/B14 Frame	10-pole	N/A	A101990-9	A101990-9
		90 Frame	10-pole	N/A	A101990-17	A101990-17
6	1	Drive magnet assembly w/set screw				
		56C (56C ATEX not available)	12-pole	N/A	A101990-15	A101990-15
		63 Frame	12-pole	N/A	A101990-16	A101990-16
		71/B14 Frame	12-pole	N/A	A101990-13	A101990-13
		80/B14 Frame	12-pole	N/A	A101990-14	A101990-14
		90 Frame	12-pole	N/A	A101990-18	A101990-18
6A	1	Knurled point set screw	All	N/A	J104219	J104219
6B	1	Cone point set screws	All	N/A	J104220	J104220
7	1	Impeller housing O-ring				
		Viton	All	N/A	J102389	J102389
		EPDM	All	N/A	J102585	J102585
8	1	Discharge O-ring				
		Viton	KC5.5,6,6H	BSP	J102390	J102390
		EPDM	KC5.5,6,6H		J102712	J102712
8	1	Discharge O-ring		BSP		
		Viton	KC8,10		J102391	J102391
		EPDM	KC8,10		J102713	J102713
9A	6	1/4-20 x 2 1/4" lg.SS Phillips pan head screws	All	N/A	J102484	J102484
9B	6	1/4" SS split lock washer	All	N/A	J100672	J100672
9C	6	1/4" SS SAE flat washer	All	N/A	J100113	J100113
10A	4	3/8 -16 x 1" SS hex head cap screw - 56C frame	All	N/A	J100114	J100114
		5mm - 25mm SS hex head cap screw - 63 frame			J103198	J103198
		6-16mm SS socket head cap screw- 71 and 80 frame (metric)			J102884	J102884
10B	4	3/8" SS split lock washer – 56C frame	All	N/A	J100115	J100115
		1/4" SS lock washer – 63, 71, & 80 frame	All	N/A	J100672	J100672
10C	4	3/8" SS flat washer – 56C frame	All	N/A	J100128	J100128
		1/4" SS flat washer – 63, 71, & 80 frame	All	N/A	J100113	J100113
11	2	Plug for motor adapter	All	N/A	J102878	J102878

TROUBLESHOOTING

GENERAL NOTES:

1. Do not pump liquids containing metal fines.
2. Orient the discharge port to either 12 or 9 o'clock position.
3. If magnets de-couple, stop the pump immediately. The rare earth magnets used in this pump are more resistant to demagnetization than ceramic magnets, but operating the pump with the magnets de-coupled will eventually weaken the magnets.
4. Plastic pumps will expand and contract with temperature so periodically check and hand-tighten screws. This pump is designed to accept an o-ring on the discharge flange and inlet chamfer as a backup to the NPT or BSP threads to ensure leak-free operation after temperature cycling.
5. Fitting o-rings on discharge flange and inlet chamfer is possible.

NO DISCHARGE

1. Air leaks in suction piping.
2. Pump not primed.
3. Discharge head too high.
4. Suction lift too high or insufficient NPSHA. Suction lift should be 2 feet above NPSHR.
5. Closed valve.
6. Viscosity or specific gravity too high (magnets uncoupled).

INSUFFICIENT DISCHARGE

1. Air leaks in suction piping.
2. Discharge head higher than anticipated.
3. Suction lift too high or insufficient NPSHA. Suction lift should be 2 feet above NPSHR.
4. Clogged suction line, foot valve or crimp in hose.
5. Foot valve too small.
6. Foot valve or suction opening not submerged enough.
7. Incorrect pump rotation.

INSUFFICIENT PRESSURE

1. Air or gasses in liquid.
2. Impeller diameter too small.
3. Discharge head higher than anticipated.
4. Incorrect pump rotation.

LOSS OF PRIME

1. Leaking suction or discharge line.
2. Suction lift too high or insufficient NPSHA. Should be 2 feet above NPSHR.
3. Air or gasses in liquid.
4. Foreign matter in impeller.
5. Leaking valve.

EXCESSIVE POWER CONSUMPTION

1. System head lower than rating. Pumps too much liquid.
2. Specific gravity or viscosity of liquid pumped is too high or higher than that defined in application.
3. Binding pump parts.

VIBRATION/NOISE

1. Excess bearing wear.
2. Drive magnet uncoupled.
3. Loose magnet.
4. Pump cavitating.
5. Motor or piping not properly secured.
6. Foreign object in impeller.

WARRANTY

Finish Thompson Inc. warrants this pump product to be free of defects in materials and workmanship for a period of one year from date of purchase by original purchaser. If a warranted defect occurs, which is determined by manufacturer's inspection, within this period, it will be repaired or replaced at the manufacturer's option, provided (1) the product is submitted with proof of purchase date and (2) transportation charges are prepaid to the factory. Liability under this warranty is expressly limited to repairing or replacing the product or parts thereof and is in lieu of any other warranties, either expressed or implied. This warranty applies only to normal wear or the product or components. This warranty does not apply to products or parts broken due to, in whole or in part, accident, overload, abuse, chemical attack, tampering, or alteration. The warranty does not apply to any other equipment used or purchased in combination with this product. The manufacturer accepts no responsibility for product damage or personal injuries sustained when the product has been modified or altered in any way. If this warranty does not apply, the purchaser shall bear all costs for labor, material and transportation.

Manufacturer shall not be liable for incidental or consequential damages including, but not limited to, process down time, transportation costs, costs associated with replacement or substitution products, labor costs, product installation or removal costs, or loss of profit. In any and all events, manufacturer's liability shall not exceed the purchase price of the product and/or accessories.

CHEMICAL REACTION DISCLAIMER

The user must exercise primary responsibility in selecting the product's materials of construction, which are compatible with the fluid(s) that come(s) in contact with the product. The user may consult Finish Thompson, Inc. (manufacturer) and a manufacturer's representative/distributor agent to seek a recommendation of the product's material of construction that offers the optimum available chemical compatibility.

However neither manufacturer nor agent shall be liable for product damage or failure, injuries, or any other damage or loss arising out of a reaction, interaction or any chemical effect that occurs between the materials of the product's construction and fluids that come into contact with the product's internals.



FINISH THOMPSON INC.

921 Greengarden Road • Erie, PA 16501-1591 U.S.A.
Ph 814-455-4478 • Fax 814-455-8518
Email fti@finishthompson.com • www.finishthompson.com

Service 800-888-3743
J102714, Rev.14, 5-16-07
FT96-606N

