



GP11 SERIES Sealed Non-Metallic Centrifugal Pumps

Installation and Maintenance Instructions

ASSEMBLY

Unpack pump from carton and check for shipping damage.

PUMPS WITH MOTOR

No assembly required. Simply unpack the pump and motor and examine for any shipping damage. If damage is detected, save the packaging and notify the carrier immediately.

Remove the shipping plugs from the suction and discharge of the pump and proceed to the "Installation Requirements" section of these instructions.

PUMPS WITHOUT MOTORS

56C/145TC and Metric Motor Adapter

1. Unpack the pump and examine for any shipping damage. If damage is detected, save the packaging and notify the carrier immediately. Use the "Supplied and Optional Parts" section of these instructions to verify that all items have been received.
2. Prepare to install the pump onto the motor.
 - a. Remove the protective shroud (Item 22) from the motor adapter (item 6).
 - b. Ensure that the set screws in shaft adapter (Item 20) are loosened to avoid interference when installing.
 - c. Coat the motor shaft with an anti-seize compound prior to installation.
3. Properly adjust the spacing between the impeller (item 3) and the housing cover (item 2).

NOTE: Proper spacing of the Impeller to the housing cover is critical for performance and to avoid damage to pump components. A .050" gap is required.

- a. Slide the shaft adapter onto the motor shaft until the impeller is tight against the inside of the housing cover (look through the pump's discharge to verify). Make sure that the shaft adapter's set screws do not line up into the motor shaft's key way.
- b. Temporarily bolt the motor adapter to the motor, placing shims (flat washer - item 10) between the motor adapter and the motor using two hex-head cap screws (Item #11) 180° apart (see Figure 1).
- c. Tighten the four set screws from the shaft adapter onto the motor shaft.

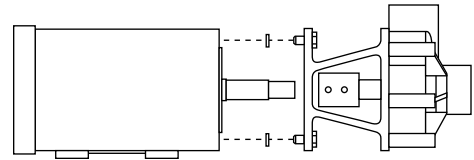

Figure 1

- d. Remove the two temporary hex-head cap screws and shim washers.
4. Pull the motor adapter flush against the motor face. Install four hex-head cap screws and flat washers through the motor adapter and into the motor and tighten.
5. Verify there is a .050" gap between the impeller and housing cover by looking into the discharge of the pump.
6. Reinstall the protective shroud.
7. Install the pump into your system according to the "Installation Requirements" section of these instructions.

56J Motor Adapter

1. Unpack the pump and examine for any shipping damage. If damage is detected, save the packaging and notify the carrier immediately. Use the "Supplied and Optional Parts" section of these instructions to verify that all items have been received.
2. Prepare to install the pump onto the motor.
 - a. Ensure that the two set screws in impeller's shaft (Item 3) are loosened to avoid interference when installing.
 - b. Slide the slinger ring (Item 18) onto the motor shaft.
 - c. Coat the motor shaft's threads with an anti-seize compound prior to installation.
3. Install the pump onto the motor.

NOTE: A special tool is available to simplify installation of pumps to "J" frame motors. Order part number A100669.

- a. Slide the pump onto motor shaft. Turn the whole pump clockwise into motor shaft until the impeller begins to slide and no longer tightens (insert a screwdriver into the motor's fan to keep the motor from turning).
- b. Mount the motor adapter to the motor's face using four hex-head cap screws and flat washers (items 10 and 11).
- c. Remove the impeller housing (Item 1) by removing the housing's six hex head cap screws (Item 11).

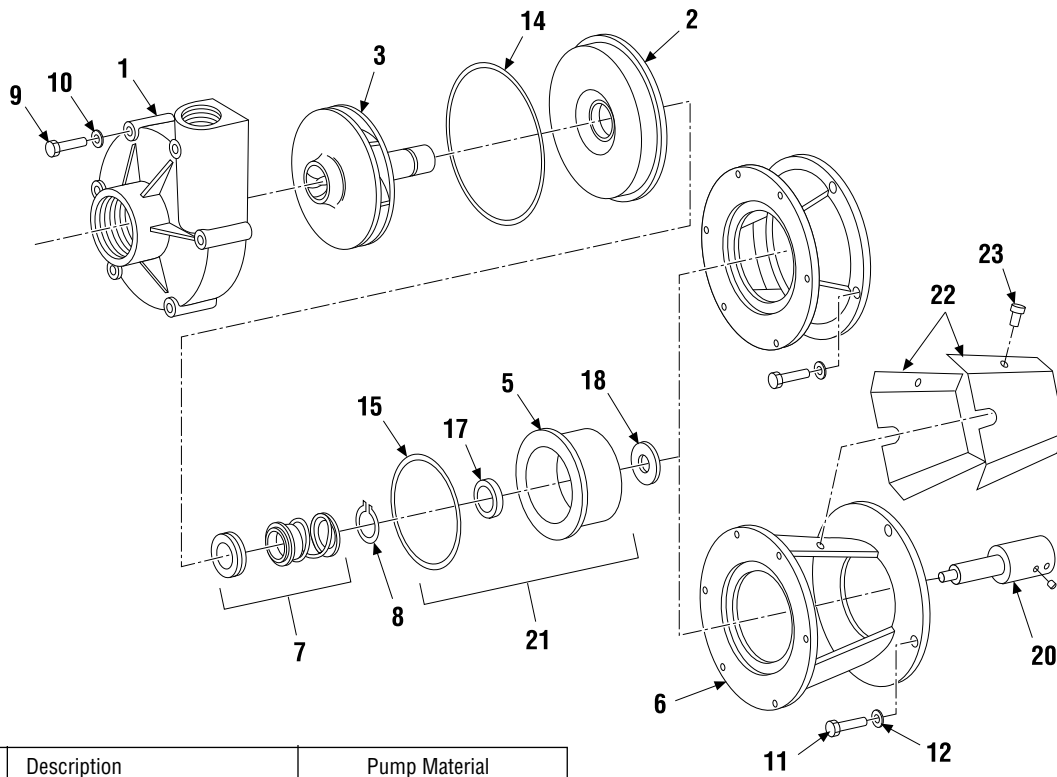

Item	Qty.	Description	Pump Material	
			Polypropylene	CF PVDF
1	1	Impeller Housing	M100101-1	M100101-2
2	1	Housing Cover	M100109-1	M100109-2
3	1	Impeller 2-1/2" PVDF Single Seal	A101705-3	
3	1	Impeller 3-1/2" PVDF Single Seal	A101705-2	
3	1	Impeller 4-1/2" PVDF Single Seal	A101705-1	
3	1	Impeller 2 1/2" PVDF Double Seal	A101705-6	
3	1	Impeller 3 1/2" PVDF Double Seal	A101705-5	
3	1	Impeller 4 1/2" PVDF Double Seal	A101705-4	
5	1	Cooling/Pressure Collar	M100112	
6	1	56C/145TC Motor Adapter	M101572-1	
6A	1	56J Motor Adapter	M101699	
6B	1	80 Frame Motor Adapter	M101572-2	
6C	1	90 Frame Motor Adapter	M101572-3	
7A	1	Bellows Seal - C/R/V	J100108	
7B	1	Multi Spring Seal - C/RH/V	J100109	
7C	1	Double Seal - C/R/V, C/R/V	J100110	
8	1	SS Retaining Ring	J100111	
9	6	1/4 - 20 x 2-3/4 SS Hex Bolt	J100112	
10	6	1/4 SS SAE Flat Washer	J100113	
11	4	3/8-16 x 1 SS Hex Head Cap Screw	J100114	
11A	4	M6 x 25mm SS Hex Head Cap Screw - 80 frame	J103456	
11B	4	M8 x 25mm SS Hex Head Cap Screw	J103662	

Item	Qty.	Description	Pump Material	
			Polypropylene	CF PVDF
12	4	3/8 SS Lock Washer	J100115	
12A	4	1/4" SS Lock Washer	J100672	
12B	4	M8 SS Lock Washer - 90 frame	J102282	
14	1	Housing O-Ring - Viton	J100116	
14A	1	Housing O-Ring - EPDM	J100117	
15	1	Cooling Collar O-Ring - Viton	J100118	
15A	1	Cooling Collar O-Ring - EPDM	J100119	
†17	1	Cooling Collar Seal	J100120	
18	1	Slinger Ring	M100115	
19	2	10-32 X 1/8 SS Set Screws (for impeller)	J100121	
20	1	56C Frame Shaft Adapter w/Set Screws	A100856	
20A	1	143TC/145TC Frame Shaft Adapter w/Set Screws	A100857	
20B	1	Metric 80 Frame Shaft Adapter w/Set Screws	A100859	
20C	1	Metric 90 Frame Shaft Adapter w/Set Screws 1/4-20 x 1/4 SS Knurled	A100860	
20D	4	Cap Point Set Screw (for use with Shaft Adapter)	J100220	
21	1	Cooling Collar Assembly	A100185	
22	1	Protective Shroud - Left Side	M101637-1	
22A	1	Protective Shroud - Right Side	M101637-2	
23	2	10-32 x 1/2 Round Head Screw	J100932	

NOTE:
 All GP Series pumps use PVDF Impellers.
 Special seals are available. Contact FTI or your local distributor for further information.
 † Used with single or multi-spring seals only.

- d. Grasp the impeller and finish tightening by hand. Tighten the impeller's set screws through the access hole in the top of the motor adapter (use a 3/32 T-handle hex wrench).
4. Reinstall the impeller housing with its six hex-head cap screws and lock-washers.

⚠ CAUTION: Do not over tighten. Torque to 90 in-lb.

5. Ensure that there is a .050" gap between the housing cover and Impeller by looking through the discharge of the pump.
NOTE: Proper spacing of the impeller to the housing cover is critical for performance and to avoid damage to pump components.
6. Install the pump into your system according to the "Installation Requirements" section of these instructions.

INSTALLATION MOUNTING

Motor or base plate must be securely fastened.

PIPING

- Always support the piping near the pump to minimize stress and strain on the pump's casing.
- Minimize frictional losses by increasing the piping size by one diameter.
- Use a minimal number of bends, keeping any bends at least a distance of ten pipe diameters away from the pump.
- Install valves on the suction and discharge lines. Place the valves within a distance of ten pipe diameters away from the pump.
- Ensure that the piping is leak free.
- Position the pump as close to the liquid source as possible.
- Maintain a flooded suction at all times.

PUMPS WITH COOLING (PRESSURE) COLLARS

A cooling collar provides a water flush to the pump's seal. This is necessary when pumping hot liquids or liquids that tend to build up or crystallize around the seal faces. If your pump is supplied with a cooling collar, proper water flow and pressure are critical to the operation of the pump.

1. Plumb a water supply to the cooling collar. Use 1/8" NPT threaded holes for the water inlet and drain lines. Either hard pipe or flexible tubing is suitable.
2. Adjust the water flow and pressure of the flush/cooling water BEFORE starting the pump.
 - For pumps with bellows or multi-spring seals, supply one to two gallons water flow per hour at 1 - 2 psi.
 - For pumps with a double seal, supply one to two gallons per hour water flow at 5 - 10 psi ABOVE the discharge pressure of the pump.

⚠ CAUTIONS:

1. Never run a pump equipped with a cooling collar without a proper water supply. Doing so will result in damage to the pump. Use of a flow switch is recommended.
2. Do not over-pressurize the cooling collar's water supply. Doing so can result in damage to pump components.

SPECIAL PIPING SITUATIONS

SUCTION LIFT

1. Install a priming chamber on the feed side of the pump or appropriate piping on the discharge for priming the pump.
2. Install a foot valve on the bottom of the suction piping to maintain a prime to the pump.

⚠ CAUTION: Suction prime must be maintained at all times.

Running the pump dry will cause damage to pump components. To protect the pump if prime is lost, use a pressure switch on the discharge, a vacuum switch on the suction, or a motor minder to monitor motor current draw.

PUMPING LIQUIDS WHICH MAY SOLIDIFY OR CRYSTALLIZE

Add a flush system to the pump's piping to prevent accumulation of material inside the pump. Install water inlet and outlet valves as shown in Figure 2. Refer to the "Operation" section of these instructions for the flush procedure.

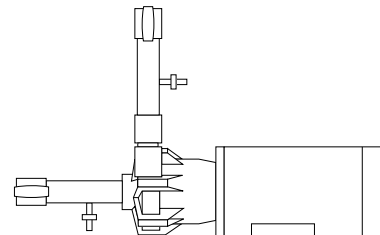

Figure 2

ELECTRICAL CONNECTIONS

1. Perform the motor wiring according to NEC requirements and local electrical codes.
2. Wire the motor for counter clockwise rotation when facing the face of the motor .

⚠ CAUTION: Before starting the pump, momentarily "jog" the motor while looking through the suction of the pump to determine if the motor is wired for the correct rotation. Refer to the directional arrow on the pump.

OPERATION

FLOODED SUCTION SYSTEMS

1. Fully open the suction and discharge valves.
2. If a cooling collar is used, turn on the cooling water.
3. Start the pump and verify liquid is flowing. If there is no liquid flow, refer to the “Troubleshooting” section of these instructions.
4. Adjust the flow rate and pressure by regulating the discharge valve.

⚠ CAUTION: Never attempt to adjust the liquid flow with the suction valve. Limiting the suction will result in damage to pump components.

SUCTION LIFT SYSTEMS

1. Fully open suction and discharge valves.
2. If a cooling collar is used, turn on the cooling water.
3. Prime the pump by filling the priming chamber. Allow time for any trapped air in the suction piping to escape.
4. Start the pump. Adjust the flow rate and pressure by regulating the discharge valve.

⚠ CAUTION: Never attempt to adjust the liquid flow with the suction valve. Limiting the suction will result in damage to pump components.

FLUSH SYSTEMS

1. Fully close the suction and discharge valves.
2. Connect the water supply to the water inlet valve and connect a drain hose to water outlet valve.
3. Turn on the water supply and open the inlet and outlet valves. Flush the system until the pump has been cleared of any material buildup (approximately 5 minutes).
4. Close the inlet and outlet valves and turn off water supply.

SEALS

SEAL REMOVAL AND INSPECTION

1. Disconnect the piping and electrical power from the pump.
2. Disassemble the pump from the motor adapter.
 - a. Remove the six hex-head cap screws from the impeller housing. The impeller housing will loosen if gently tapped at the discharge outlet.
 - b. Remove the protective shroud from the motor adapter. Loosen the two set screws from the impeller's shaft.
 - c. While preventing the motor shaft from moving (insert a screwdriver into the motor's fan), unscrew the impeller from the motor shaft. Remove the impeller, seal, cooling collar (if applicable) and housing cover as one assembly from the motor shaft.

NOTE: For pumps using a 56C/145TC or motor adapter, leave the shaft adapter secured to the motor shaft.

3. Remove the seal for inspection.

- a. Lubricate the Impeller's shaft with a rubber lubricant emulsion or soapy water to allow the seal to slide easier.

NOTE: Never use a petroleum product for lubrication. Doing so will effect the seal elastomer's performance after reassembly.

- b. If no cooling collar is present, carefully remove the retaining ring that holds the rear of the seal. If equipped with a cooling collar, carefully slide the cooling collar off of the Impeller's shaft.
 - With single bellows or multi-spring seals, a retaining ring holds the seal in place. Carefully remove the retaining ring.
 - With double seals, the cooling collar holds the seal in place.

⚠ CAUTION: The seal's spring is compressed and under pressure. Use care when removing.

- c. Remove the seal's spring. Grasp the rotating head of the seal by hand and twist to remove from the impeller's shaft.
 - d. Remove the housing cover from the impeller.
 - e. Press the ceramic stationary seat portion of the seal out of the housing cover.
4. Visually inspect all parts for damage. Replace any parts that appear worn or damaged.
 - Look for scoring of the seal's ceramic face.
 - Inspect the rotating seal face for wear.
 - Check for degradation or chemical attack of any elastomers and other seal components.
 - Look for signs of heat damage (melted plastic) to the Housing Cover and Impeller's shaft.

SEAL INSTALLATION AND PUMP REASSEMBLY

Single Bellows Seal

1. Install the stationary seal face.
 - a. Lubricate the stationary face's o-ring with a rubber lubricant emulsion or soapy water. Keep the polished surfaces of the seal face clean.

NOTE: Never use a petroleum product for lubrication. Doing so will effect the seal elastomer's performance after reassembly.
 - b. Carefully press the stationary face into the housing cover (use a piece of cardboard to protect the seal while pressing against the stationary face). The smoothest side of the stationary face should be facing outward.
2. Install the rotating face.
 - a. Lubricate the impeller's shaft with a rubber lubricant emulsion or soapy water.
 - b. Carefully slide the housing cover over the Impeller's shaft. The side of the housing cover with the pressed-in seal face should be away from the impeller.
 - c. Separate the rotating head of the seal from the large

spring. Relubricate the impeller's shaft, then carefully slide the rotating head of the seal over the Impeller's shaft using a twisting motion. The carbon side of the rotating face should be toward and pressed against the stationary head of the housing cover.

⚠ CAUTION: The carbon portion of the seal is easily damaged. Take care not to apply uneven force or crack the carbon while installing.

3. Install the seal's spring and spring retainer. Compress the spring and snap the retaining ring (item #8) into the groove on the Impeller's shaft.
4. Install the assembled seal, impeller and housing cover onto the motor bracket.
 - a. If a cooling collar is being used, slide it onto the Impeller's shaft at this time. Take care to align the water connections so they are accessible.
 - b. Screw the impeller onto the motor shaft or Shaft Adapter and tighten the impeller's set screws.
 - c. Make certain that the housing cover's o-ring is in place.
 - d. Place the impeller housing into position and install the hardware. Tighten the six hex-head cap screws to 90 inch-pounds.

Multi-Spring Seal

The basic installation procedure for a multi-spring seal is the same as for the single bellows seal. The exception is that a multi-spring seal has 4 set screws which need to be tightened on the Impeller shaft.

Double Seal

1. Remove the motor adapter from the motor's face (the pump has previously been removed).
2. Install the stationary seal faces.
 - a. Lubricate the stationary faces' o-rings with a rubber lubricant emulsion or soapy water. Keep the polished surfaces of the seal face clean.
NOTE: Never use a petroleum product for lubrication. Doing so will affect the seal elastomer's performance after reassembly.
 - b. Carefully press the stationary faces into the housing cover and the cooling collar (use a piece of cardboard to protect the seal while pressing against the stationary face). The smoothest side of the stationary face should be facing outward.
NOTE: If using a special seal material, it is vital that the special stationary seal face is pressed into the housing cover.
3. Install the rotating faces and cooling collar to the motor adapter.
 - a. Carefully slide the housing cover over the impeller's shaft. The side of the housing cover with the pressed-in seal face should be away from the impeller.
 - b. Separate the rotating head of the seal from the spring.

NOTE: If using a special seal material, it is vital that the special seal face mates against the housing cover's stationary face.

- c. Lubricate the impeller's shaft, then carefully slide the rotating face of the seal over the Impeller's shaft using a twisting motion. The carbon or special side of the rotating face should be toward and pressed against the stationary face of the housing cover.

⚠ CAUTION: The carbon or special portion of the seal is easily damaged. Take care not to apply uneven force or crack the carbon or special material while installing.

- d. Place the seal's spring into position on top of the installed rotating face.
- e. Relubricate the impeller's shaft and then carefully slide the second rotating face of the seal over the Impeller's shaft using a twisting motion (the carbon side of the second rotating face should be facing away from the other rotating face). This will require some compression of the seal's spring.
- f. Place the cooling collar's o-ring into position. Slide the cooling collar onto the Impeller's shaft, with the stationary face in the cooling collar pressed against the second rotating face. Continue to slide the cooling collar until it mates against the housing cover. Hold the cooling collar in this position. Take care to align the water connections so they are accessible.

NOTES:

1) The seal's spring must be compressed further in order to mate the cooling collar and housing cover.

2) Take care not to pinch the cooling collar's o-ring. If the o-ring is not properly seated, the cooling collar will leak.

4. Place the pump components onto the motor adapter. While holding the cooling collar against the housing cover, install the assembly into the motor adapter. The motor adapter will hold the cooling collar in place. It will now be necessary to hold the impeller to keep the seal's spring compressed.
5. Carefully place the assembly in position to the motor's face.
 - a. Screw the impeller onto the motor shaft or shaft adapter. It will be necessary to hold the motor's fan with a screw driver to keep the motor shaft from turning.
 - b. Align the motor adapter so that the access hole is straight up.
 - c. Install and tighten the Impeller's set screws through the access hole in the motor adapter (it will be necessary to turn the impeller to expose the holes in the impeller's shaft).
 - d. Bolt the motor adapter to the motor using the hex-head cap screws and lock-washers.
 - e. Double check the alignment of the water connection holes in the cooling collar.

6. Install the impeller housing.
 - a. Install the housing cover's o-ring.
 - b. Place the impeller housing into position and install the hardware. Tighten the six hex-head cap screws to 90 inch-pounds.
 - c. Look through the discharge of the pump to verify proper spacing between the impeller and the housing cover. If using a 56C or metric motor adapter, adjust the shaft adapter if necessary (refer to the "assembly" section of these instructions).

TROUBLESHOOTING

NO OR INSUFFICIENT FLOW

1. Pump not primed.
2. Closed valve.
3. Viscosity too high.
4. Air leaks in suction piping.
5. Discharge head higher than anticipated.
6. Suction lift too high or insufficient NPSH. Check also for clogged suction line.
7. Motor wired for wrong rotation.

INSUFFICIENT PRESSURE

1. Air or gasses in liquid.
2. Impeller diameter too small.
3. Discharge head higher than anticipated.
4. Motor wired for wrong rotation.

LOSS OF PRIME

1. Leaking suction line.
2. Foot valve or suction opening not submerged enough.
3. Foot valve too small or leaking.
4. Air or gasses in liquid.
5. Foreign matter in impeller.

EXCESSIVE POWER CONSUMPTION

1. Head lower than rating. Excessive flow.
2. Specific gravity or viscosity of liquid is too high.

EXCESSIVE VIBRATION

1. Loose piping or bolts.
2. Pump cavitating from improper suction or feed.

WARRANTY

Finish Thompson, Inc (manufacturer) warrants this pump product to be free of defects in materials and workmanship for a period of one year from date of purchase by original purchaser. If a warranted defect, which is determined by manufacturer's inspection, occurs within this period, it will be repaired or replaced at the manufacturer's option, provided (1) the

product is submitted with proof of purchase date and (2) transportation charges are prepaid to the manufacturer. Liability under this warranty is expressly limited to repairing or replacing the product or parts thereof and is in lieu of any other warranties, either expressed or implied. This warranty does not apply to normal wear of the product or components. This warranty does not apply to products or parts broken due to, in whole or in part, accident, overload, abuse, chemical attack, tampering, or alteration. The warranty does not apply to any other equipment used or purchased in combination with this product. The manufacturer accepts no responsibility for product damage or personal injuries sustained when the product is modified in any way. If this warranty does not apply, the purchaser shall bear all cost for labor, material and transportation.

Manufacturer shall not be liable for incidental or consequential damages including, but not limited to process down time, transportation costs, costs associated with replacement or substitution products, labor costs, product installation or removal costs, or loss of profit. In any and all events, manufacturer's liability shall not exceed the purchase price of the product and/or accessories.

CHEMICAL REACTION DISCLAIMER

The user must exercise primary responsibility in selecting the product's materials of construction, which are compatible with the fluid(s) that come(s) in contact with the product. The user may consult Finish Thompson, Inc. (manufacturer) and a manufacturer's representative/distributor agent to seek a recommendation of the product's material of construction that offers the optimum available chemical compatibility.

However neither manufacturer nor agent shall be liable for product damage or failure, injuries, or any other damage or loss arising out of a reaction, interaction or any chemical effect that occurs between the materials of the product's construction and fluids that come into contact with the product's internals.

ORDERING SPARE PARTS

Spare parts can be ordered from your local distributor. Always refer to pump model number to avoid error.

OTHER FTI PRODUCTS

Drum Transfer Pumps are available in sanitary construction, stainless steel, polypropylene and CPVC. Flows to 40 gpm, discharge heads to 80 feet and viscosities to 100,000 cP.

Portable Mixers for turbine mixing and blending handle viscosities to 1,000 cP with gentle, non-vortex circulation. Available in 316 stainless steel construction.

Sealed Centrifugal Pumps in polypropylene, CF PVDF, 316 SS, and Hastelloy C come with a wide variety of sealing materials. Flows to 250 gpm, discharge heads to 130 feet and temperatures to 200°F (104°C).

Sealless Mag Drive Centrifugal Pumps in polypropylene, CF PVDF and ductile cast iron. Flows to 330 gpm and discharge heads to 325 feet. Handle temperatures up to 220°F (104°C) and have 30 minute run-dry capability. Mount to standard frame motors.

For further information, contact Finish Thompson Inc. or your local distributor.



FINISH THOMPSON INC.
 921 Greengarden Road • Erie, PA 16501-1591 U.S.A.
 Ph 814-455-4478 • Fax 814-455-8518
 Email fti@finishthompson.com • www.finishthompson.com

TECH SERVICE 1-800-888-3743
 Literature ID No. FT00-788H
 Part Number J102486, Rev 10, 4-23-09

