

# ULTRACHem<sup>®</sup> Series

ANSI DIMENSIONAL MAGNETIC DRIVE PUMPS

## UC SERIES: MODEL UC1518

### PERFORMANCE

3450 rpm, 60 Hz

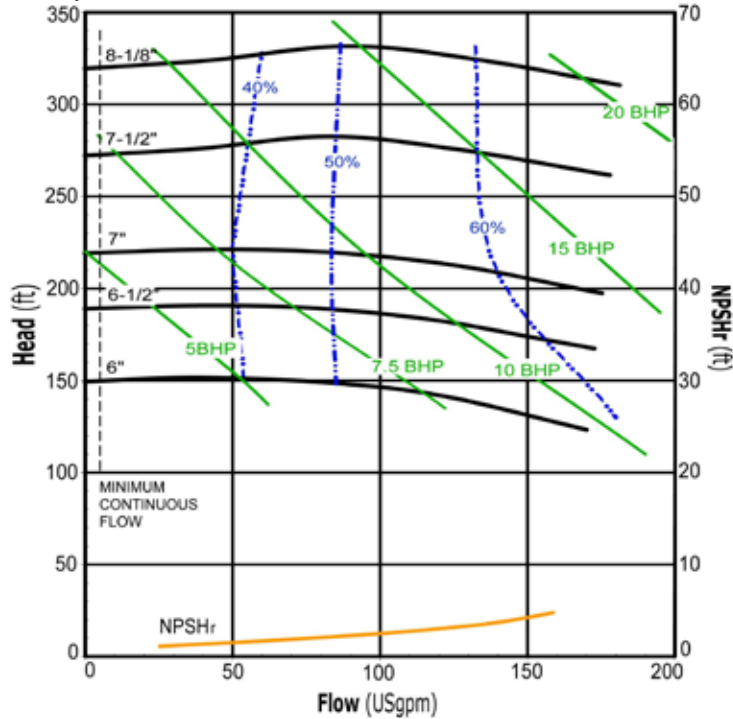

2900 rpm, 50 Hz

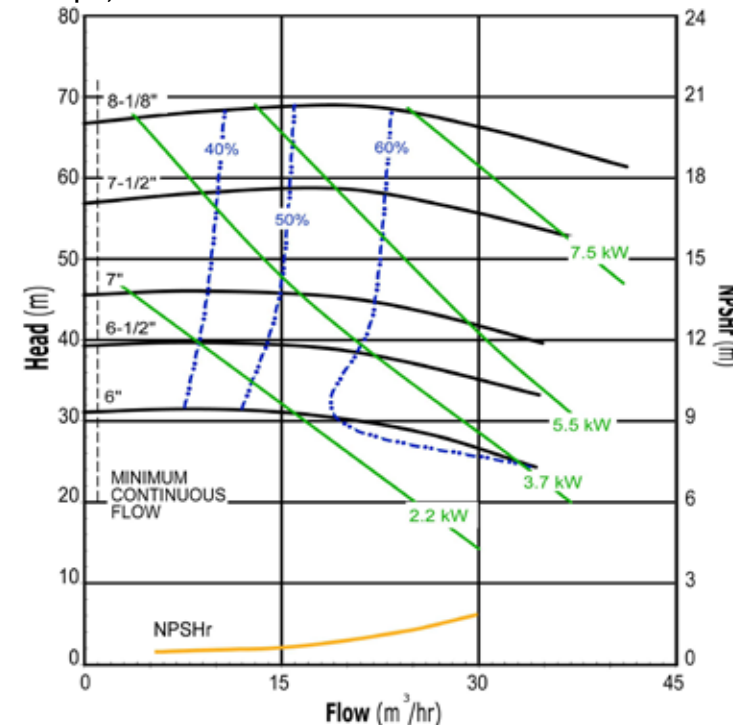

\* Patent No. 5,779,456

### FEATURES

- Durable, corrosion-resistant Tefzel<sup>®</sup> lined ductile iron casing
- Casing meets ANSI B73.1m for foot and flange location
- Powerful neodymium magnets drive the impeller for dependable, leak-free operation with no environmental emissions
- Modified concentric volute reduces radial thrust load
- Rear sealing ring and balance holes balance axial thrust
- Dual bushings provide optimum alignment
- Carbon-filled ETFE shaft support with integral straightening vanes helps prevent pre-rotation in the suction and enhances low flow operation
- Easy-set measurement free outer drive
- Back pull-out design
- Casing drain connection standard
- Run dry capability with carbon bushing and SiC dri-coat
- Specific gravity over 1.8
- Accepts standard NEMA 143-45, 182-84, 213-15, 256 or IEC 90, 100/112, 132, 160 motor frames
- ANSI or ISO flange mountable
- ATEX certified models available

### TYPICAL APPLICATIONS

- Chemical manufacturing, blending, distribution
- Water treatment
- Plating and metal finishing
- Paper mills
- Fume scrubbers
- Metals manufacturing
- Electronics
- Pharmaceuticals
- Biodiesel

### TYPICAL CHEMICALS

- Sodium hydroxide
- Sulfuric acid
- Hydrochloric acid
- Sodium hypochlorite
- Plating solutions
- Corrosive blends
- Solvents
- Wastewater

\*Tefzel<sup>®</sup> Fluoropolymer Resin is a registered trademark of DuPont



Item No.	Description	Construction
1	Casing	Cast ductile iron, DuPont Tefzel® (ETFE) lined
2	Shaft support	Carbon fiber filled ETFE
2A	Front thrust ring	Alpha sintered silicon carbide
3	Impeller	Carbon fiber filled ETFE
3A	Impeller thrust washer	Fluorosint®, alpha sintered silicon carbide optional
4	Inner drive	Neodymium iron boron magnets encapsulated in pure ETFE
4A	Bushing options	Alpha sintered silicon carbide, carbon
4B	Bushing spacer	PTFE
4C	Rear sealing ring	Molybdenum disulfide-filled PTFE
5	Shaft	Alpha sintered silicon carbide
6	Barrier	Molded carbon fiber filled ETFE liner with woven glass reinforced vinyl ester external shell
6A	Barrier thrust ring	High purity alumina ceramic
7	Clamp ring	Steel
8	Outer drive magnet	Nickel-plated neodymium iron boron magnets/steel
9	Motor adapter	Ductile iron
10	O-ring options	FKM, EPDM, Kalrez®, Simriz®

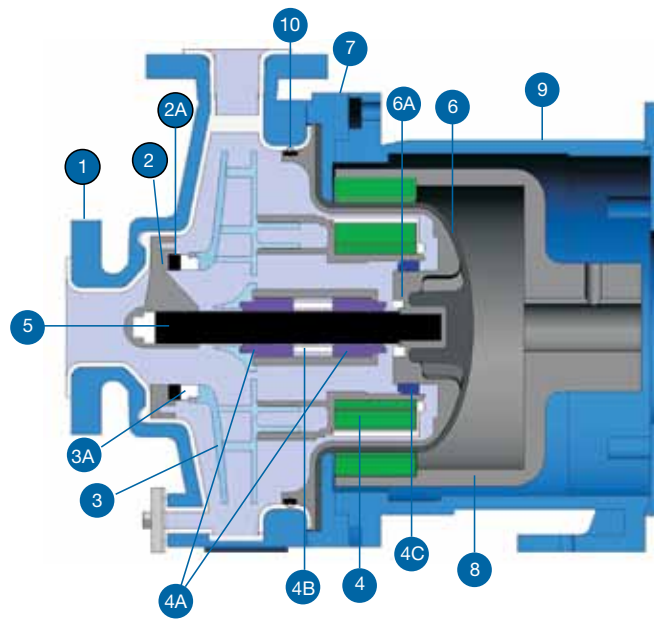

Kalrez® is a registered trademark of DuPont Performance Elastomers  
 Simriz® Perfluoroelastomer is a registered trademark of Simrit® division of Freudenberg-NOK.

## SPECIFICATIONS

HP (kW)	Impeller Diameter		Suction in (cm)	Discharge in (cm)	Max. Flow 3500 rpm gpm m <sup>3</sup> /hr	Max. Head 3500 rpm ft. m		Max. Working Pressure psi (Bar)	Max. Viscosity cP	Max. Sp. Gravity	Max. Temp. °F (°C)
	in	cm				ft.	m				
3 - 20 (1.1 - 15.0)	6, 6-1/2, 7, 7-1/2, 8-1/8	15.2, 16.5, 17.8, 19, 20.6	1-1/2 (3.81)	1 (2.54)	181.3 41.2	331.7 101.1	175 (12)	200	1.8	250 (121)	

Note: Impeller trims available every 1/8" (.32 cm) between the smallest and largest diameters.

## DIMENSIONS

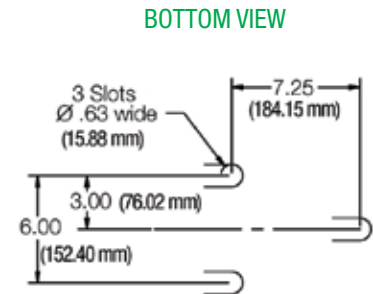
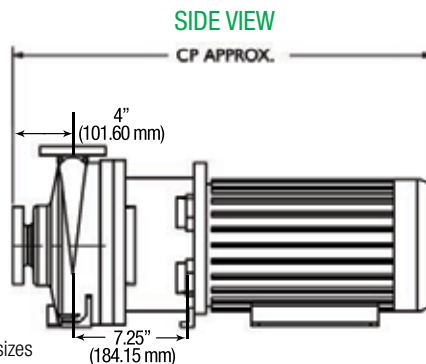
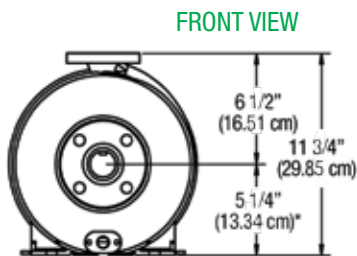

\*Contact the factory for 132/160 dimension. All other frame sizes are as shown above. Dimensions are for reference only.

Motor Frames	CP			
	A-Drive (in)	B-Drive (in)	A-Drive (cm)	B-Drive (cm)
<b>NEMA</b>				
143-145TC	23-3/4	-		
182/184TC	28-1/16	29-1/16		
213/215TC	30-1/2	32-1/4		
254/256TC	-	36-3/4		
<b>IEC</b>				
90			61.7	-
100/112			67.5	-
132			73.9	76.5
160			-	86.0

## ACCESSORIES

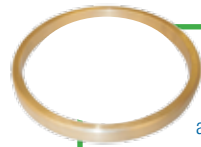

**Bronze Bump Ring** - add to the motor adapter to make pump suitable for hazardous areas.



**SIC Dri-Coat** (for shaft and bushings) is ideal protection for applications where the pump may see unintentional, brief periods of dry running.



**M20 Power Monitor** - Shuts the pump down when there is a drop in power to prevent run dry damage.

**Baseplate** - fabricated of steel or fiberglass for extra strength and rigidity. Suitable for grouting. Shown with optional bearing frame.

