

# MSKC Series

MULTI-STAGE MAGNETIC SEALLESS PUMPS

## MSKC Sealless Centrifugal Pumps

1 1/2 to 3 HP  
(.55 to 1.5 kW)

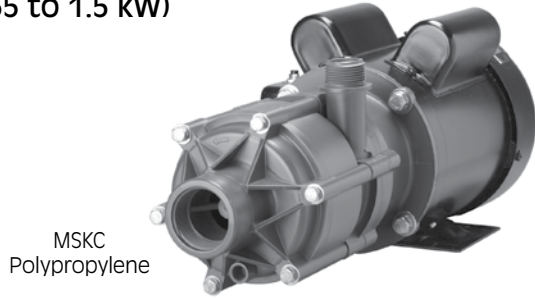

## Features

- Sealless mag drive technology - eliminates costly seal problems
- Multi-Stage design: Generates increased head at low flow rates, low power consumption, wide hydraulic envelope allows for mix and match impeller sizes
- Small footprint - avoids large impeller diameters
- Unique interconnecting drive shaft - transmits torque from magnetic coupling to first stage impeller
- Independent thrust bearings at each stage for maximum reliability
- Polypropylene or PVDF construction
- Accepts standard NEMA 56C or IEC 71/B14, 80/B14 frame motors
- Maximum working pressure 80 psi
- Maximum temperature: 180°F (82°C) - Polypropylene  
220°F (104°C) - PVDF
- Maximum flow 60 gpm (12.8 m<sup>3</sup>/hr.), maximum head 100 ft. (21.3 m)

**Multi-Stage is also available in a vertical design.**

## Performance

Note: numbers 1, 2, 3, 4, 5 on curves indicate impeller diameter combinations. See specifications

### 60 Hz 3450 rpm

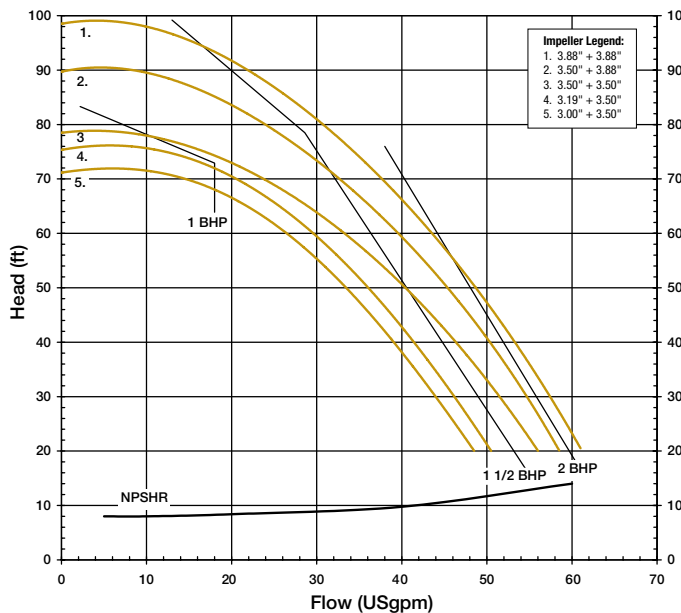

### 50 Hz 2900 rpm

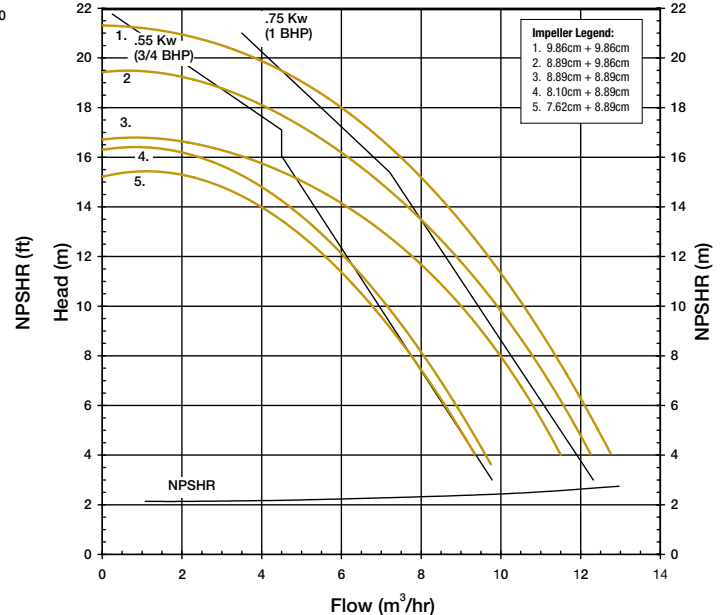

## Specifications

MODEL* (CONSTRUCTION)	SUCTION DISCHARGE	IMPELLER SIZE		MAX. FLOW		MAX. HEAD		MOTOR DRIVE		MAX. S.G. @ 50 cps
		inch	cm	3450 rpm gpm	2900 rpm m <sup>3</sup> /hr	3450 rpm ft	2900 rpm m	3450 rpm hp	2900 rpm kw	
MSKC1 (P, V)	1-1/2" FNPT/BSP  1" MNPT/BSP	3.88+3.88	9.86+9.86	61	12.7	99	21.3	3	1.1	1.5
MSKC2 (P, V)		3.50+3.88	8.89+9.86	59	12.2	90	19.4	2	1.1	1.5
MSKC3 (P, V)		3.50+3.50	8.89+8.89	56	11.5	79	16.7	2	.75	1.5
MSKC4 (P, V)		3.19+3.50	8.10+8.89	51	9.7	75	16.2	1.5	.75	1.8
MSKC5 (P, V)		3.00+3.50	7.62+8.89	49	9.3	71	15.2	1.5	.55	1.8

P - Polypropylene glass filled - maximum temperature 180°F (82°C).

V - PVDF carbon filled - maximum temperature 220°F (104°C).

Note: Actual performance may vary with conditions.

## Dimensions

MODEL	MOTOR FRAME	A*		B*		C		D	
		inch	cm	inch	cm	inch	cm	inch	cm
MSKC	56C	6-1/2	16.5	8	20.3	3-1/2	8.89	10-9/32	26.11
	71 IEC	4-1/8	10.5	8	20.3	2-13/16	7.10	10-9/32	26.11
	80 IEC	4-23/32	12	9	22.9	3-5/32	8.0	10-9/32	26.11

\*Varies with motor manufacturer

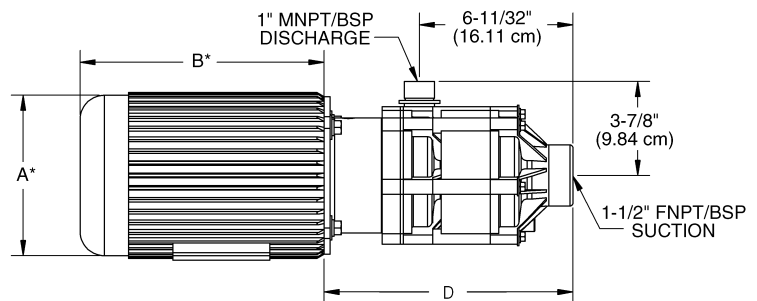
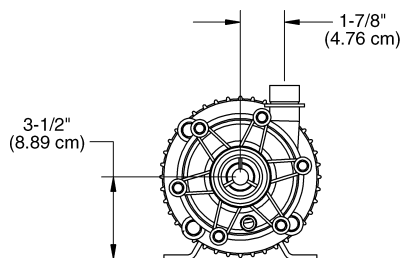
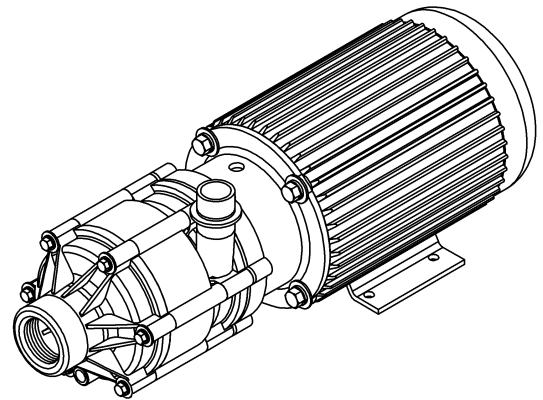

**FINISH THOMPSON INC.**

921 Greengarden Road • Erie, PA 16501-1591 U.S.A.  
Ph 814-455-4478 • Fax 814-455-8518  
Email [fti@finishthompson.com](mailto:fti@finishthompson.com) • [www.finishthompson.com](http://www.finishthompson.com)

Toll Free USA & Canada 1-800-934-9384  
Literature I.D. No. - FT01-844E 6/29/10

