

# KC Series

MAGNETIC SEALLESS PUMPS

## KC11 Sealless Centrifugal Pumps

1.0 to 3.0 Hp  
(.55 to 2.2 kW)



KC11 PP



KC11 PVDF

## Features

- 24-hour run-dry capability with carbon bushing
- Polypropylene or PVDF
- Excellent chemical resistance
- Mounts to standard NEMA 56C, 145TC or IEC 80 or 90 frame motors with B14
- NPT or BSP threads
- Rugged cantilevered ceramic spindle
- Back pull-out design for easy service
- 1.8 specific gravity
- 50 cps maximum

## Performance

60 Hz 3450 rpm

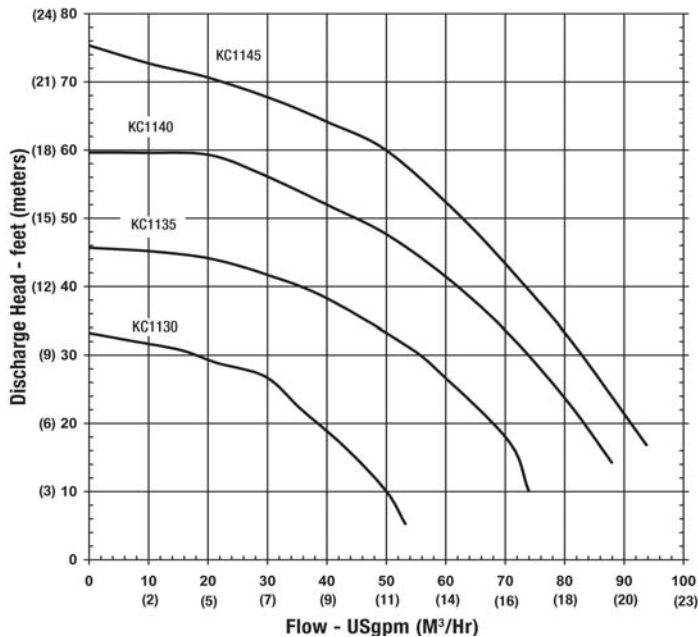

50 Hz 2900 rpm

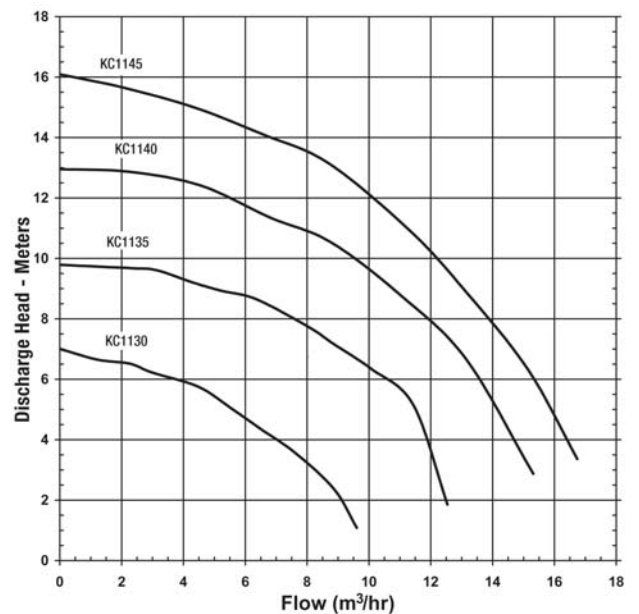

# Specifications

MODEL (CONSTRUCTION)	SUCTION DISCHARGE	IMPELLER SIZE		MAX. FLOW			MAX. HEAD			MOTOR DRIVE	
		inch	cm	3450 rpm		2900 rpm	3450 rpm		2900 rpm	3450 rpm	2900 rpm
				gpm	m <sup>3</sup> /hr	m <sup>3</sup> /hr	ft	m	m	hp	kW
KC1130	1-1/2" FNPT 1-1/4" MNPT	3.0	7.6	53	12	9.6	33	10	7.0	1.0 - 1.5	.55 - .75
KC1135		3.5	8.9	74	17	12.5	46	14	9.8	1.5 - 2.0	.75 - 1.1
KC1140		4.0	10.2	88	20	15.3	60	18	13.0	1.5 - 3.0	.75 - 2.2
KC1145		4.5	11.4	94	21	16.7	75	23	16.1	2.0 - 3.0	1.1 - 2.2

P - Polypropylene glass filled, carbon, PTFE, high purity ceramic and Viton®. Maximum temperature 180°F (82°C).

V - PVDF carbon filled, carbon, PTFE, high purity ceramic and Viton. Maximum temperature 220°F (104°C).

NOTE: (1) Actual performance may vary. Pump models and performance vary with conditions.

(2) Maximum working pressure: 35 psi - polypropylene construction, 45 psi - PVDF construction

\*Viton is a registered trademark of DuPont Dow Elastomers.

## Dimensions

Close Coupled

Pedestal Mounted

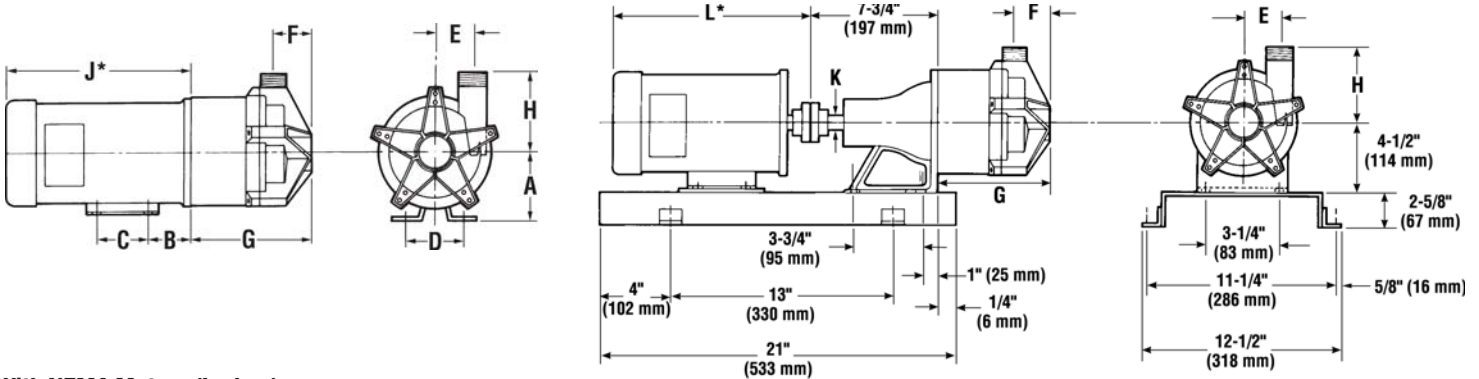

With NEMA Motors (Inches)

MODEL	MOTOR FRAME	A	B	C	D	E	F	G	H	J*	K	L*
KC11	56C	3-1/2	2-3/4	3	4-7/8	2-1/4	2-3/8	7-1/2	4-3/4	12-1/8	3/4	14
	145TC			5	5-1/2							15

With IEC Motors (Millimeters)

MODEL	MOTOR FRAME	A	B	C	D	E	F	G	H	J*	K	L*
KC11	80	80	50	100	125	57	60	191	121	230	19	268
	90	90	56	125	140					250		312

\* Varies by manufacturer



**FINISH THOMPSON INC.**

921 Greengarden Road • Erie, PA 16501-1591 U.S.A.

Ph 814-455-4478 • Fax 814-455-8518

Email [fti@finishthompson.com](mailto:fti@finishthompson.com) • [www.finishthompson.com](http://www.finishthompson.com)

Toll Free USA & Canada 1-800-934-9384

Literature I.D. No. FT98-705D, 4-05

